



Brandon Historic District Guidelines

City of Brandon, Mississippi
Historic Preservation Commission



Amended November 19, 2018

Copyright 2015
The Mayor and Aldermen
of the City of Brandon, Mississippi

This publication has been financed in part with Federal Funds from the National Park Service, U.S. Department of the Interior, through the Historic Preservation Division of the Mississippi Department of Archives and History. However, the contents and opinions do not necessarily reflect the views or policies of the Department of the Interior or the Mississippi Department of Archives and History, nor does the mention of trade names, commercial products or consultants constitute endorsement or recommendation by these agencies.

This program received Federal financial assistance for identification and protection of historic properties. Under Title VI of the Civil Rights Act of 1964, Section 504 of the Rehabilitation Act of 1973, and the Age Discrimination Act of 1975, as amended, the U.S. Department of the Interior prohibits discrimination on the basis of race, color, national origin, disability or age in its federally-assisted programs. If you believe you have been discriminated against in any program, activity, or facility as described above, or if you desire further information, please write to:

Office of Equal Opportunity
National Park Service
1849 C Street, N.W.
Washington, D.C. 20240

These guidelines were prepared for the
Brandon Historic Preservation Commission

Penny Schooler, Chairperson
Joan Alliston, Co-Chairperson
Christal Jenkins, Secretary
Jeff Carrothers
Jan Harrell
Justin Rhodes
Melanie Thortis
Jennifer Waits

These guidelines were prepared by the
Vicksburg Foundation for Historic Preservation
2015

CONTENTS

Acknowledgements

I. Introduction	7
A. Purpose of the guidelines	9
B. Brandon's Preservation Goals	10
C. Secretary of the Interior Standards	11
D. How to use these guidelines	13
II. The History and Architecture of Brandon, Mississippi	15
III. Certificate of Appropriateness Process	23
IV. Routine Repair and Maintenance	29
V. Residential Buildings: Standards and Guidelines for Rehabilitation and Restoration	37
A. Roofs	38
B. Siding	40
1. wood	
2. masonry	
3. stucco	
4. architectural metals	
5. synthetic siding	
C. Architectural ornamentation	46
D. Porches and balconies	47
E. Steps and railings	51
F. Foundations and crawl space enclosures	52
G. Windows	53
H. Doors	58
I. Awnings	61
J. Paint	62
K. Lighting	63
L. Mechanical systems	64
M. Fences and walls	65
N. Landscaping and yard features	68
O. Driveways and parking lots	69
P. Additions and decks	71
VI. Commercial Buildings: Standards and Guidelines for Rehabilitation and Restoration	73
A. Roofs	75
B. Siding	78
1. masonry	
2. stucco	
3. architectural metals	
C. Architectural ornamentation	83
D. Balconies	84
E. Windows	86

CONTENTS

F. Doors	91
G. Awnings	94
H. Wood and metal canopies	95
I. Lighting	96
J. Mechanical systems	97
K. Parking lots	98
L. Additions	100
VII. Outbuildings: Standards and Guidelines for Rehabilitation and Restoration	101
VIII. Signs	105
IX. New Construction: Residential and Commercial	111
A. General guidelines	113
B. Residential new construction	115
C. Commercial new construction	120
D. Outbuildings	129
X. Handicap Access and Fire Escapes	131
XI. Other Issues That Require a Certificate of Appropriateness	135
A. Relocation	137
B. Demolition	138
C. Securing Vacant Buildings	139
Appendix	141
A. Glossary of architectural and historic preservation terms	
B. Resources	

ACKNOWLEDGEMENTS

In early 2000, it was realized that Brandon had already passed a turning point. Its architectural heritage was being lost at an alarming rate through demolition and insensitive alterations. Interested citizens recognized that these historic buildings were a visual link to the past that represented elements of the city's cultural, social, economic, and political history. It was further acknowledged that the only way to ensure that Brandon's heritage would be preserved for future generations was to adopt an ordinance that provided for the establishment of historic districts and a commission to oversee the rehabilitation of properties within those districts.

As a result of this concern, the Mayor and Aldermen adopted the Certified Local Government Ordinance in August, 2003 and designated a historic district in October, 2004. The Commission realized that extensive and comprehensive guidelines were needed to help guide property owners and the Commission in making the appropriate decisions regarding historic buildings and new construction.

We are most grateful to one of our first commission members, Marjorie Murray, who was instrumental in the adoption of the Certified Local Government Ordinance. She came to Brandon in 1948 and adopted our city, and Brandon has been greatly rewarded for this. It is in her memory that we dedicate this publication.

Cover photo- courtesy of the Rankin County News.

Line drawings by Andy Bell.

INTRODUCTION



PURPOSE OF GUIDELINES

During the past few decades, interest in historic preservation and the rehabilitation of historic structures has grown in the United States. Increasingly, people are beginning to realize the value of historic structures and the contributions that they make to a community. Historic buildings represent a visual record of the architectural and social history of our city. These historic structures serve as links to the past and as tangible reminders of the people and events that shaped the development of the city. They have a story to tell about its past, and what better way to illustrate that story than through the city's historic resources.

The purpose of the Brandon Design Guidelines is to encourage historic preservation and appropriate design standards in Brandon's historic district in order to protect and promote the city's architectural heritage and unique character. The guidelines do not emphasize historically perfect restoration. They attempt to foster "respectful rehab" – rehabilitation and routine maintenance that retain the distinctive features of older buildings while recognizing that buildings must keep living and changing to suit contemporary needs. The guidelines are consistent with the preservation principles established by the United States Department of the Interior as expressed in the Secretary of the Interior's Standards for Rehabilitation.

Use of the guidelines will assist the commission in making uniform and fair decisions that are consistent with the Secretary of the Interior's Standards for Rehabilitation and sound preservation practice. Property owners, architects, and contractors can use the guidelines to plan their projects with reasonable assurance that their applications will be approved if the guidelines are followed.

The Brandon Historic Preservation Commission is responsible for regulating exterior changes in the city's locally designated historic district. The Brandon Design Guidelines address only the exterior of historic resources and focus on the architectural features that define the unique character of Brandon. Therefore, the commission will use the Design Guidelines and the Secretary of the Interior's Standards for Rehabilitation in making decisions about which changes are appropriate and which changes are inappropriate. A property owner planning to construct a new building or contemplating changes to the exterior of a historic resource must first obtain a Certificate of Appropriateness before work can begin. If the proposed physical change is consistent with the Design Guidelines and Secretary of the Interior's Standards, the applicant will receive a Certificate of Appropriateness and work can begin after all permits are received from other city departments.

The Brandon Design Guidelines, used in harmony with the Brandon Preservation Ordinance, will assist the Historic Preservation Commission in protecting and preserving local historic resources. The guidelines do not provide case-specific advice. They are a general guide for changes to historic structures and the design of new construction. The conditions and characteristics of each building and the appropriateness of proposed alterations will be examined on a case-by-case basis. The final authority does not rest with the Brandon Design Guidelines, but with the involved property owners, architects, contractors, municipal authorities and members of the Brandon Historic Preservation Commission. They ultimately determine the appropriateness of changes within any locally designated historic district.

BRANDON’S PRESERVATION GOALS

Brandon’s preservation goals are outlined in the Statement of Purpose in the Brandon Preservation Ordinance, as follows:

“As a matter of public policy the city aims to preserve, enhance, and perpetuate those aspects of the city having historical, cultural, architectural, and archaeological merit. Such preservation activities will promote and protect the health, safety, prosperity, education, and general welfare of the people living in and visiting Brandon.”

More specifically, this historic preservation ordinance is designed to achieve the following goals;

- Protect, enhance and perpetuate resources that represent distinctive and significant elements of the city’s historical, cultural, social, economic, political, archaeological, and architectural identity;
- Insure the harmonious, orderly, and efficient growth and development of the city;
- Strengthen civic pride and cultural stability through neighborhood conservation;
- Stabilize the economy of the city through the continued use, preservation, and revitalization of its resources;
- Protect and enhance the city’s attractions to tourists and visitors and the support and stimulus to business and industry thereby provided;
- Promote the use of resources for the education, pleasure, and welfare of the people of the City of Brandon;
- Provide as review process for the preservation and appropriate development of the city’s resources.

The Brandon Design Guidelines will assist the city in fulfilling these goals by providing guidance for owners of historic properties, design professionals, contractors, and members of the Preservation Commission. Preserving Brandon’s historic resources is essential to maintaining Brandon’s unique identity and special sense of place.

SECRETARY OF THE INTERIOR STANDARDS

The City of Brandon Historic District Guidelines are based on the Secretary of the Interior's Standards for rehabilitation which were developed to help property owners and developers in planning successful rehabilitation projects. Successful projects extend the life of historic resources through the preservation of historic materials and features, and make possible an efficient contemporary use. The Standards pertain to historic buildings of all materials, construction types, sizes, and occupancy and include related landscape features, sites, and environment.

Rehabilitation is defined as the process of returning a property to a state of utility, through repair or alteration, which makes possible an efficient contemporary use while preserving those portions and features of the property which are significant to its historic, architectural, and cultural values. Following the Standards during a rehabilitation project will ensure that repairs and alterations will not damage or destroy materials, features, or finishes that are important in defining the building's historic character.

The following are the Secretary of the Interior's Standards for Rehabilitation:

1. A property shall be used for its historic purpose or be placed in a new use that requires minimal change to the defining characteristics of the building and its site and environment.
2. The historic character of a property shall be retained and preserved. The removal of historic materials or alteration of features and spaces that characterize a property shall be avoided.
3. Each property shall be recognized as a physical record of its time, place, and use. Changes that create a false sense of historical development, such as adding conjectural features or architectural elements from other buildings, shall not be undertaken.
4. Most properties change over time; those changes that have acquired historic significance in their own right shall be retained and preserved.
5. Distinctive features, finishes, and construction techniques or examples of craftsmanship that characterize a property shall be preserved.
6. Deteriorated historic features shall be repaired rather than replaced. Where the severity of deterioration requires replacement of a distinctive feature, the new feature shall match the old in design, color, texture, and other visual qualities and, where possible, materials. Replacement of missing features shall be sustained by documentary, physical, or pictorial evidence.
7. Chemical or physical treatments, such as sandblasting, that cause damage to historic materials shall not be used. The surface cleaning of structures, if appropriate, shall be undertaken using the gentlest means possible.
8. Significant archaeological resources affected by a project shall be protected and preserved. If such resources must be disturbed, mitigation measures shall be undertaken.
9. New additions, exterior alterations, or related new construction shall not destroy historic materials that characterize the property. The new work shall be differentiated from the old and shall be compatible with the massing, size, scale, and architectural features to protect the historic integrity of the property and its environment.
10. New additions and adjacent or related new construction shall be undertaken in such a manner that if removed in the future, the essential form and integrity of the historic property and its environment would be unimpaired.

SECRETARY OF THE INTERIOR STANDARDS

When applying these Standards, there are four levels of rehabilitation that should be considered when planning a rehabilitation project within the district. The following approaches to rehabilitation projects are used throughout the Brandon Design Guidelines and will be used by the Preservation Commission during their review process.

1. Identify, retain, and preserve the form and detailing of those architectural materials and features that are important in defining the historic character.
2. Protect and maintain those materials and features that are important and must be retained in the process of rehabilitation work. Protection generally involves the least degree of intervention and is preparatory to other work. Protection may include the maintenance of historic material through treatments such as rust removal, caulking, limited paint removal, painting, cyclical cleaning of roof gutter systems, or roof repair.
3. Repair should be considered next when the physical condition of character-defining materials and features warrants additional work. Repair is best accomplished with least degree of intervention possible such as patching, piecing-in, splicing, consolidating, or otherwise reinforcing or upgrading according to recognized preservation methods. Repairing also includes the limited replacement in kind of extensively deteriorated or missing parts of features when there are surviving prototypes.
4. Replacement of an entire character-defining feature with new material because of the level of deterioration or the damage to materials precludes repair, is the last resort and should only be considered if the feature cannot be reasonably repaired and thus preserved. If the essential form and detailing are still evident so that the physical evidence can be used to re-establish the feature as an integral part of the rehabilitation project, then the feature should be replicated in kind, with the same materials.

HOW TO USE THESE GUIDELINES

The Brandon Design Guidelines are intended to be easy to use and allow for quick reference of specific information. The guidelines are divided into topical sections with each section further divided into subsections in order to locate specific information more quickly.

These guidelines are based on the Secretary of the Interior's Standards for Rehabilitation and are therefore referenced in each section. Preservation Briefs are also referenced so that an applicant can find additional information about a rehabilitation topic. They can be obtained through the National Park Service website.

The key to a successful rehabilitation is respecting the historic character of the building and preserving as many of the original historic materials and details as possible. Alterations should be easily reversible, which will allow a future owner to return the building to its original configuration. Owning a historic building is a privilege and a responsibility. Owners of historic properties should view themselves as temporary caretakers of a piece of our community's architectural heritage.

We believe that because these design guidelines are based on solid preservation practices, they will stand the test of time and will still be in use years from today. However, while we believe these guidelines are all encompassing, we also believe that this is a living document that should be enhanced and updated when occasions arise.

**THE HISTORY AND ARCHITECTURE
OF
BRANDON, MISSISSIPPI**



HISTORY

Brandon is the county seat for Rankin County and is located twelve miles east of Jackson, just off Interstate 20. Historically it was on the line of the Alabama and Vicksburg Railroad and for several years was the terminus of the Vicksburg-Meridian Railroad. According to Dunbar Rowland in History of Mississippi: The Heart of the South, “Brandon was at one time the most important trading points in this section of the state” (p. 818).

Brandon’s importance as a trading point was first established by the many tribes of Native Americans who inhabited the southeast. This site was centrally located near the crossing of the north-south and the east-west Indian trails leading to various villages, and was used for council meetings and other events. The area was rich in game and dotted with springs. It was located on a spring near the intersection of two early territorial roads; one heading north through Madison County, crossing the Natchez Trace and heading toward Cairo, Illinois and south to Mobile, Alabama; and the other road toward the Mississippi River to the west and then east to Hillsboro, Scott County, and on toward central Alabama.

Traders, missionaries, and early settlers also camped near what is now the town square. Soon a blacksmith and repair shop were built to meet the needs of the travelers. The best of overnight accommodations for man and livestock could be found at the trading post owned by D. W. Wilkerson in the early 1820s and 30s, located on College Street. The town continued to grow with commercial buildings being constructed on the town square and to the east and west on Government Street.

In 1828, Rankin County was carved out of Hinds County and named in memory of the late Christopher Rankin, a distinguished lawyer and politician who served Mississippi in Congress from 1819 until his death in 1826. The site for Brandon was chosen as the seat of the new county because it was the highest point in the new county and centrally located. Originally proposed to be named Poindexter, the name Brandon was chosen to honor the new governor of Mississippi. Gerard Chittocque Brandon was a native of Natchez and had been lieutenant governor for both Governors Leake and Holmes. Brandon was elected governor in 1827 over four opponents and was widely known as a man of ability, character, and culture. In addition, he was Mississippi’s first native-born governor.

On July 24, 1828, Daniel Fore bought 79.75 acres from the United States Government, this land being the current downtown area of Brandon. Fore and his wife deeded forty acres to the town with an understanding that a courthouse would be erected in the center of the public square. The land was square, 1320 feet on each side and was divided into four quarters. Brandon grew quickly as is evidenced by an 1838 article in the “Republican and Eastern Advocate” where editors stated that Brandon “was an insignificant little village three years ago with perhaps a courthouse, a store, a lawyer and a physician. Now it is surpassed by few towns in the state. Probably no town is improving faster than Brandon is at this time. There have been not less than 175 to 200 carpenters daily at work here during the winter.”

Rankin County’s first courthouse was built in the center of the Brandon Square in 1833. The two-story log building as demolished when it became too small for its purpose and needed repairs. The county records were moved to the Brandon Bank located on the southwest corner of the square. The bank burned in 1851, and a residence on College Street served as the courthouse until a new courthouse, was completed in 1853 on a location west of the public wells.

Because Brandon was the county seat and an important trade center, several hotels and taverns were built to accommodate the many people who came there to transact business. One of the earliest of these was the Union Hotel, built in 1836 in the southwest quarter of town. The Chester House, originally called the Shelton House,

HISTORY

was built in 1838 and was located on the corner of Main and Timber streets. It was a two and a half story building with galleries on the first and second floor. Contemporary with these hotels were several saloons, including the Gem Saloon, housed in a two-story frame building on the south side of the public square and the “Old Tavern,” in operation by 1842.

By 1837, Brandon had a variety of commercial activities, including three dry goods stores, a lumber company, and a grocer/provisioner, in addition to Fore’s grist mill and two smithies. By 1842, eight merchants were listed in Brandon, and more stores opened in 1844 and 1845. Brandon was also the county’s major medical center and had at least four doctors by 1837.

Churches were established in Brandon soon after the town was incorporated. These included Brandon Baptist Church in 1835, Brandon Methodist in 1836, and St. Luke’s Episcopal in 1848. Brandon Presbyterian Church was formally organized in 1851, but Presbyterians had been meeting there since 1847. Until their church was built on Poindexter Street, the Methodists met at the courthouse. The Methodist Church was used as a hospital during the Civil War, until it was burned in 1863. After which, the congregation met in the Brandon Female College building until the new church was completed in 1873. The Brandon Baptists also met in the College until their first building was completed in 1882.

As was the case in many Mississippi towns, the railroad was a factor in the early development of Brandon. The Jackson and Brandon Railroad and Bridge Company was chartered in 1836, with a bank in Brandon financing the enterprise. The bank failed during the Panic of 1837 and the project was suspended. The company was reincorporated in 1841, but failed again. The same year, the legislature approved the incorporation of the Mississippi and Alabama Railroad and transferred the holdings of the Jackson to Brandon Company to it. A narrow gauge railroad line from Jackson to Brandon opened in 1849. Once the railroad was completed, cut rates encouraged riders to travel to Brandon to enjoy the curative waters found at Baugh’s Wells. Baugh’s Wells and Busick’s Mineral Wells were believed to contain iron, sulfur, and magnesium. Doctors touted their healing powers and visitors stayed at the Union Hotel and the Chester House, both built in 1836. These curative waters were an economic boom for about 50 years until the waters ran out. In 1852, the Mississippi and Alabama Railroad assets were transferred to the Southern Railroad Company and they completed the railroad through Meridian to the Alabama line in 1860. The railroad ran through Brandon with a deep cut made south of and parallel to Government Street. The track ran past the Methodist Church on College Street to a turntable in McCaskill’s pasture. Then the railroad received financing to extend the line to Meridian, there was a disagreement about the right of way in town and to the east of town. The railroad company removed the track from the center of town to its western edge and began looking for another route. Sometime between 1850 and 1860, the depot burned and railroad officials decided to move the depot one mile north of Brandon. Local historical information maintains that many Brandon residents were glad to have the depot moved, as they objected to the noise and other unpleasant features of the trains. The removal of the railroad from the center of town probably slowed Brandon’s growth, however.

During the Civil War, Brandon felt the full wrath of General Sherman’s Army as it marched through Jackson to Vicksburg. Most of the town was burned by the Union soldiers and most private homes were looted or burned during the period in which Federal troops occupied the town. The courthouse was set on fire, but its stone and concrete construction caused it to burn slowly and the fire was extinguished. The Methodist Church, the post office, the government stables, and buildings on all but the west side of the square were burned. General Sherman used four, two-story buildings known as the Wilkerson Block on the west of the square as his headquarters. Much of what was destroyed was not rebuilt.

HISTORY

For several years after the Civil War, the area's transportation and agricultural processing systems were disrupted and the population of Rankin County decreased. Both the black and white populations of Mississippi increased between 1860 and 1870, but Rankin County's white population decreased by 826 and its black population increased by 168. It is estimated that about 440 Rankin County soldiers died during the Civil War; the balance of the population loss was probably due to out-migration. Brandon's population also declined from 1850 to 1870, and the town's economy undoubtedly suffered somewhat as a result of the population decline. Despite this change, a pamphlet produced by the Vicksburg and Meridian Railroad noted that "Brandon is the largest and perhaps the most important place on the road between Jackson and Meridian; has always been remarkable for its good society, fine schools, and churches. Has a large weekly newspaper, the 'Brandon Republican,' quite a number of first-class business houses, and other facilities." Another indication of the town's regained economic prosperity during this period was the construction of new buildings for the Methodist church in 1873, the Baptist church in 1882, and the Episcopal church in the 1880s.

In the late 1890s, the Gulf and Ship Island Railroad was built across Rankin County, just south of Brandon. While the railroad did not run through Brandon, the town benefited from the 600 laborers who came to the county to build the railroad and from the sale of timber which was used for railroad ties.

Brandon continued its tradition as a center for medical services in the county with the construction of the Brandon Sanatorium, a hospital for the treatment of tuberculosis, on the northwest corner of the intersection of Government and College streets. The facility, which included a training school for nurses, was only in operation until 1913. After which, it was used as an apartment house until the 1920s when it was used as a hotel and then as a hospital again until 1956. The building was destroyed by fire in 1986.

While Rankin County's economy was based on agriculture, it was not a single crop economy. The boll weevil infestations which ravaged the cotton crops in the state from 1907 to 1916 caused a decline in the county's agricultural income, but the economy was sustained by timber, cereal, and fruit crops. Rankin County's population declined from 1910 to 1920, losing 726 whites and 2,946 blacks, probably due to out-migration of farm laborers. Brandon's population also declined during this period, but the economy remained relatively stable, sustained by its government functions and related services.

Brandon, like many other southern towns in the early years of the twentieth century, participated in the extensive effort to memorialize the Confederacy. Beginning in 1904, the Brandon chapter of the United Daughters of the Confederacy had solicited donations, held fundraising events, and asked the board of supervisors in Rankin County for a contribution to help pay the \$3,000 cost of a Confederate monument. In 1907, a monument in memory of "those noble men who gave their lives and for the cause" was erected in the middle of Town Square in front of the courthouse.

The face of downtown was forever changed in 1924 when a fire destroyed the courthouse, the Chester House hotel, St. Luke's Episcopal Church, and much of the downtown. A new courthouse was built on the same site within a year. The new Classical Revival courthouse was designed by Noah Webster Overstreet, one of Mississippi's most notable architects.

Over the next twenty years (1930 to 1950) Brandon's population almost tripled from 692 to 1,827. The city continued to be a center for government and commerce and would over the next half a decade also become a bedroom community for nearby Jackson. The city annexed parts of the county and by 1990 the population had

HISTORY

increased to 11,077. The downtown area continues to be the heart of the community and the county. While large shopping areas have been constructed in the outlying areas, the downtown is still dominated by the courthouse, major banking concerns, the local newspaper, and churches. Even though the downtown area has experienced trying times and has lost a number of its historic resources through fires and demolition, it retains its integrity of location, feeling, and association through the wealth of intact historic resources which span the history of Brandon.

Important people to have hailed from Brandon include two governors: Robert Lawry (1882-1890) and Anselm J. McLaurin (1896-1900) and Mary Ann Mobley, who was the first Mississippian to be crowned Miss America (1959). Brandon also claims to have furnished the state of Mississippi with more governors, senators, congressman, judges, district attorneys, physicians and teachers than any other town its size in the state. Brandon has often been called the “City of red hills laden with golden opportunities.”

ARCHITECTURE

RESIDENTIAL RESOURCES

Brandon's residential resources reflect a wide range of traditional house types and architectural styles. Residences are generally one, one and a half, or two stories and largely of wood frame construction. The houses built with wood frame construction most often have weatherboard wall treatment. Brick veneer is also found alone or in combination with other materials on houses built in the twentieth century. If present, stone or cast stone are used sparingly for architectural details such as porch piers, lintels, and window and door sills.

Most of the residential resources in Brandon are house types commonly found in Southern towns and cities during this historic period, including center hall plans, L-front houses, bungalows and English- inspired cottages. A few of these resources were constructed originally as one house type and modified to the appearance of another later in the historic period.

The following residential styles are represented in Brandon's residential resources- Greek Revival, Queen Anne, Colonial Revival, Craftsman, Tudor Revival, Minimal Traditional, and Ranch.

PUBLIC INSTITUTIONAL RESOURCES

Public institutional resources have been developed by city, county, and federal governments at various times over Brandon's development. The cultural heritage of Brandon has seen the construction of buildings and related elements that have served necessary roles in providing public or private education, postal service, local government, and law enforcement. All of these structures reflect the development of Brandon's civic character and its role in the larger context of Rankin County. Many of these buildings have served a dual role as important architectural or cultural landmarks for the community.

The resources of Brandon that are included in this property type and historic context are public buildings, civic buildings, schools, law enforcement facilities, and monuments. Architectural styles associated with these resources are Neo-classical, Beaux Arts, Craftsman, Minimal Traditional and Art Moderne.

COMMERCIAL RESOURCES

Commercial resources in Brandon are one and two-story narrow-fronted, brick buildings with generally flat roofs. Many of the storefronts have been altered, but the upper stories (generally three, sometimes four bay) generally retain their original sash. Brandon has lost most of its historic commercial buildings, making those that remain highly significant to the architectural integrity of the city.

RELIGIOUS RESOURCES

The churches in the district are Gothic Revival and Romanesque Revival. The Gothic Revival style is evident with an emphasis on the vertical effect highlighted with Gothic-arched windows and doors. The Romanesque Revival style has round-arched windows and fanlights.

CERTIFICATE OF APPROPRIATENESS PROCESS



**Community Development:
Historic Preservation Commission**

APPLICATION FOR CERTIFICATE OF APPROPRIATENESS *For proposed exterior changes to property within the designated historic district*

Historic District: _____

Property Address: _____

Use of Property: _____

Applicant: _____ Owner: _____

Address: _____

Note: If the applicant is different from the owner, attach a letter authorizing application and proposed change.

Signature: _____ Phone: _____

Date: _____

Briefly describe the proposed project:

PROPOSED ALTERATIONS

- New Construction, additions or extensive renovation or repair to existing buildings
- Renovations or repair to existing buildings, including changes in design or materials of roofs, windows, doors
- Site changes: tree removal, changes to or additions to fences, walks, driveways, parking areas, signs
- Demolition or relocation

See checklist on back for required support materials for each category

NOTES

- Appropriate support materials as required for each proposed change must be submitted to complete this application.
- Incomplete applications will not be reviewed by the Brandon Historic Preservation Commission

Deadline: Applications and all support materials must be submitted by 5 p.m. seven (7) days prior to the regular Brandon Historic Preservation Commission meeting.

FOR COMMISSION USE ONLY:

RECEIVED: _____ REVIEWED: _____

APPROVED: _____ DENIED: _____

Return to the Department of Community Development, P.O. Box 1539, Brandon, MS 39043

APPLICATION PROCESS

A Certificate of Appropriateness, hereby referred to as COA, is required from the Brandon Historic Preservation Commission before any action can be taken with the Brandon Historic District or involving a Landmark site. Anyone desiring to take an action must submit an application to the Department of Community Development. Applications can be obtained on the city's website (cityofbrandon.net; click on departments; community development; and then preservation commission application). The application must be submitted to the Community Development Department who shall forward the application to the Chairman of the Historic Preservation Commission. The Commission shall review the application and make recommendations for changes and modifications, if necessary, in order to meet the Standards and Guidelines for the work to be performed. If the applicant's plans meet the Commission's approval, a signed COA will be returned to the Community Development Department.

The deadline for any application for construction, rehabilitation, or demolition of a building within the district or of a landmark site, will be eight (8) days prior to the meeting date. These applications will be considered at the next regular meeting of the Commission on the second Tuesday of each month, at 6:00 p.m. in the Brandon Public Library. The applicant or his representative must be present at the meeting.

All maintenance and repair work must meet the City of Brandon's safety standards and codes.

INFORMATION THAT MUST ACCOMPANY THE APPLICATION

NEW CONSTRUCTION, ADDITIONS, RESTORATION, OR REHABILITATION

Applications for new construction, additions to existing structures, restoration or rehabilitation of any existing structure within any locally designated historic district must include the following:

1. A set of plans and drawings showing all exterior elevations proposed for additions, alterations rehabilitation or new construction and the type of work proposed including overall dimensions, type of materials to be used on walls, roofs, windows, trim, and siding.
2. Site plan indicating property lines, setbacks, location of the structure or proposed location of a new structure, accessory building, parking facilities, exterior lighting, fencing, landscaping, and screening for utilities.
3. Drawing of proposed sign with lettering, colors, materials, lighting to be used, and dimensions.
4. Photographs of existing structure or, if for new construction, a photograph of the lot and the adjoining structures.

No application is required for minor repair or routine maintenance defined as involving removal of inappropriate or outdated signs, awnings, or canopies not original to the structure or not involving change in design, material or appearance of the building.

APPLICATION PROCESS

COMMERCIAL SIGNS

Applications for commercial signs must include the following:

1. A photograph of the building on which or in front of which the sign is to be placed, indicating the proposed location of the sign.
2. A drawing of the proposed sign detailing dimensions, material, color, type of lettering, and type of support.
3. A drawing or photograph showing how the sign will be lighted, if applicable.

FENCES, WALLS, WALKS, AND DRIVEWAYS

Applications should be submitted with the following information:

1. Drawings showing the type of fence, wall, walk, or driveway proposed with its dimensions, materials, placement on the lot and proposed color, if applicable.
2. Photographs of the property and where the new feature will be placed.

CUTTING OF A LIVE TREE

For the cutting of a live tree that is six (6) inches or greater at ground level the following information must be submitted with the application:

1. A photograph of the tree showing its relationship to the building on the lot.
2. A measurement of the diameter of the tree at ground level.
3. An explanation of why the tree is proposed to be removed.
4. A plot plan of the proposed use of the property, if applicable.

PARKING LOT

For the construction of a parking lot, the following information must be submitted with the application:

1. Plot plan showing the relationship of the proposed lot to neighboring buildings.
2. Type of paving, style of curbing and striping.

APPLICATION PROCESS

3. Type and location of lighting, if any.
4. Location and type of fencing, screening and landscaping.
5. Photographs of proposed location and neighboring buildings.

MOVING A STRUCTURE

Application for moving a structure into, out of, or within the Brandon Historic District must include:

1. Photograph of structure to be moved and its current address.
2. Method of moving the structure, photograph and address of the proposed location of the structure.
3. Statement of Need for the proposed move with reference to the future use of the site.
4. Site plans indicating property lines, setbacks, accessory buildings, parking facilities, exterior lighting, fencing, and landscaping.

DEMOLITIONS

Application for demolition of a structure shall include the following:

1. Photograph of the structure to be demolished.
2. Method of demolition to be used.
3. Statement of need for proposed demolition with reference to further use of the site.

Time Limits for all Certificates of Appropriateness

Approvals of a Certificate of Appropriateness are good for one (1) year. If work has not begun by this time, a new application must be obtained.

ROUTINE REPAIR AND MAINTENANCE



WORK THAT CONSTITUTES ROUTINE REPAIR & MAINTENANCE

Minor repair and routine maintenance is repair that does not involve a change in design, material, or other appearance. The minor repair and maintenance must be undertaken with identical materials and in such a manner as to exactly duplicate the feature that is deteriorated or damaged.

The minor repair and routine maintenance items that follow do not require review by the Commission. However, depending on the extent of the proposed work, a building permit may be required and these guidelines for routine repair and maintenance are referred to throughout the guidelines for rehabilitation.

Roofs, chimneys, and gutters

1. repairing by patching, piecing-in, consolidating or otherwise reinforcing, or by limited replacement of roofing materials, chimneys, gutters, down spouts, flashing, cupolas, vents, and dormer roofing with materials matching the original in size, shape, composition and color.
2. for repairs to chimneys see **Siding-masonry** below.
3. for repair to dormer or cupola windows, see **Windows** below.

Note: the entire replacement of roofing materials requires a Certificate of Appropriateness.

Siding-wood: clapboard, weatherboard, shingles or other wooden siding

1. painting
2. repairing by patching, piecing-in, consolidating, or otherwise reinforcing, or by limited replacement with materials matching the original in size, shape, and composition. (**For information about how to repair clapboard siding, the last page in this section.**)
3. cleaning of wood with low pressure water spray.
4. removing damaged or deteriorated paint to the next sound layer using the gentlest method possible- hand scraping and hand sanding- then repainting (paint that is firmly adhering to, and thus, protecting wood, shall not be removed).

Note: other methods of cleaning such as sand or other particle blasting and chemicals are not permitted as they damage the surface of the wood, cause pitting and hasten deterioration.

Siding-masonry: brick, stone, terra cotta, concrete, stucco

1. cleaning using low pressure water spray, detergent and natural bristle brushes, when there is no possibility of freezing temperatures. The cleaning of masonry should only be undertaken when necessary to halt deterioration or to remove heavy soiling. Cleaning masonry surfaces when they are not heavily soiled only to create a new appearance introduces moisture into the masonry needlessly.
2. repainting masonry that is already painted.

WORK THAT CONSTITUTES ROUTINE REPAIR & MAINTENANCE

original in size, shape, composition and color.

4. removing damaged or deteriorated paint to the next sound layer using the gentlest method possible- hand scraping and hand sanding- then repainting (paint that is firmly adhering to, and thus, protecting masonry, shall not be removed).

Note: a. other methods of cleaning such as sand or other particle blasting and chemicals are not permitted as they damage the surface of the masonry and mortar, cause pitting and hastening deterioration.

b. repointing masonry requires a Certificate of Appropriateness to ensure that the mortar strength, composition, texture and color are appropriate and that the method used to remove mortar meets the guidelines found in **Masonry**.

c. even though many waterproof sealants are clear and it may be assumed that the application of such would not require a Certificate of Appropriateness, the coatings are most often unnecessary and may change the appearance of historic masonry, as well as accelerate its deterioration; therefore a Certificate of Appropriateness is required before a waterproof sealant is applied.

Siding-architectural metals: lead, bronze, brass, cast iron, steel, pressed tin, copper, aluminum and zinc.

1. repainting
2. repairing by patching, piecing-in, consolidating or otherwise reinforcing, or by limited replacement with materials matching the original in size, shape, composition and color.

Note: a. cleaning shall only be undertaken after the type of metal is determined as each metal has unique properties and requires different treatments. Test patches should also be undertaken to ensure that the gentlest cleaning method is chosen. Methods of cleaning such as sand or other particle blasting and most chemicals are not permitted as they damage the surface of the metal. Because of the intricacies involved with architectural metals, cleaning them requires a Certificate of Appropriateness. See

Architectural Metals.

b. complete replacement of a feature requires a Certificate of Appropriateness.

Architectural detailing (ornamentation)

1. painting
2. repairing or replacing with materials matching the original in size, shape, composition, and color.
3. cleaning of wood with low pressure water spray

Note: a. other methods of cleaning such as sand or other particle blasting and chemicals are not permitted as they damage the surface of the ornamentation, cause pitting and hastening decay.

b. complete replacement of an architectural feature requires a Certificate of Appropriateness.

WORK THAT CONSTITUTES ROUTINE REPAIR & MAINTENANCE

Porches and Balconies: columns, balustrades, screening, flooring

1. repairing by patching, piecing-in, consolidating or otherwise reinforcing, or by limited replacement with materials matching the original in size, shape, and composition.
2. painting
3. replication of missing parts of a repeated feature such as balustrades or columns where there are surviving original examples from which to recreate the missing feature.
4. severely deteriorated flooring can be replaced with matching material, but cannot be replaced with concrete or brick
5. repairing screening or screen frames

Note: the addition of screening where it does not presently exist or the glassing-in of a porch requires a Certificate of Appropriateness.

Steps and railings

1. repairing or replacing in kind with materials matching the original in size, shape, and composition.
2. painting

Note: the addition of steps or railings where they do not presently exist requires a Certificate of Appropriateness.

Foundations and crawl space enclosures

1. repairing and replacing piers and enclosures in kind with materials matching the original in size, shape, composition and color.
2. for masonry piers see **Siding-masonry** above.

Windows, window surrounds, shutters: frames, heads, hood molds, paneled or decorated jambs and moldings

1. replace glass with clear glass
2. caulk or weather strip
3. repairing by patching and splicing or by limited replacement with materials matching the original in size, shape, composition and color.
4. painting
5. removing damaged or deteriorated paint to the next sound layer using the gentlest method possible- hand scraping and hand sanding- then repainting (paint that is firmly adhering to, and thus, protecting wood, shall not be removed).

Note: a. complete replacement of a sash, window surround or shutter requires a Certificate of Appropriateness.

WORK THAT CONSTITUTES ROUTINE REPAIR & MAINTENANCE

b. the addition of shutters, storm windows or awnings where they do not presently exist requires a Certificate of Appropriateness.

Doors and door surrounds: fanlights, sidelights, pilasters, entablatures

1. replace glass with clear glass
2. caulk or weather strip
3. repairing by patching and splicing or by limited replacement with materials matching the original in size, shape and composition.
4. painting
5. removing damaged or deteriorated paint to the next sound layer using the gentlest method possible- hand scraping and hand sanding- then repainting (paint that is firmly adhering to, and thus, protecting wood, shall not be removed).

Note: a. complete replacement of a door or surround requires a Certificate of Appropriateness.
b. the addition of storm doors or screen doors where they do not presently exist requires a Certificate of Appropriateness.

Awnings

1. repairing or replacing an awning with materials matching the original in size, shape, composition and color.

Note: the addition of awnings where they do not presently exist requires a Certificate of Appropriateness.

Painting

1. the painting of a building is considered routine repair and maintenance

Lighting

1. repairing or replacing in kind with materials matching the original in size, shape, composition, and color.

Note: the addition of lighting on a building or in a yard where lighting does not presently exist requires a Certificate of Appropriateness.

Mechanical Systems

1. installing window air conditioning units which do not damage or destroy historic windows, transoms or doors and which are not installed by cutting a hole in the side of a building. Window units should be installed on the sides or rear elevations.

WORK THAT CONSTITUTES ROUTINE REPAIR & MAINTENANCE

2. Installing exterior mechanical systems such as heat pumps or air conditioning units in the rear or on an inconspicuous side of the building and shall be shielded, see **Mechanical Systems**.

Fences, walls, bulkheads

Repairing or replacing in kind with materials matching the original in size, shape, composition and color.

Note: a. the addition of fences or walls where they do not presently exist requires a Certificate of Appropriateness.

- b. for repairs to masonry walls see **Siding-masonry**, for wooden fences and walls see **Siding-wood**, and for metal fences see **Siding-architectural metals**.

Landscaping and yard features: driveways, walkways, sidewalks, fountains, terraces, trees, swimming pools, patios, parking lots, pergolas

1. repairing or replacing in kind with materials matching the original in size, shape, composition and order.
2. cutting a tree that is LESS THAN six (6) inches in diameter.
3. the planting of trees, shrubs, or plants.

Note: the addition of any of the yard features mentioned above where they do not presently exist requires a Certificate of Appropriateness.

Signs

All signs require a Certificate of Appropriateness, whether temporary or permanent.

Storefronts

1. protecting and maintaining masonry, wood and architectural metals which comprise storefronts through appropriate treatments such as cleaning, rust removal, and painting (see specific material above for appropriate guidelines for **Siding-wood**, **Siding-masonry**, or **Siding Architectural metals**).
2. repairing by patching, piecing-in or by limited replacement with materials matching the original in size, shape, and composition.

Note: the removal of non-historic additions or alterations and subsequent restoration of the storefront requires a Certificate of Appropriateness.

WORK THAT CONSTITUTES ROUTINE REPAIR & MAINTENANCE

Repairing wooden clapboards

Minor damage to clapboards can often times be repaired without replacing the entire board. If the siding is split, pry open the split pieces with a putty knife and apply strong, waterproof, exterior wood glue along the crack or split. Press the board together and nail finishing nails above and below the split board, pointing the nails toward the split. Leave some of the nail showing so that they can be removed once the glue has dried. Use wood filler or putty to fill in the nail holes and once it is dry, sand, prime, and paint.

If clapboard is warped and is bulging out (convex), drill several holes in the board at the studs (this will be in the same area as the board is nailed). Soak the board and then insert wood screws in the holes and gradually tighten them until the board regains its original shape. Countersink the screws so that they are below the surface of the wood. Once the board is dry, putty the screw holes, sand, prime, and paint.

If clapboard is warped and cups in (concave), drill holes at the top and bottom of the board. Nail it flat with finishing nails, putty, sand, prime, and paint.

If a section of clapboard is rotten or damaged beyond repair, remove the nails in the section and those in the board above it. Cut through the section with a saw and use a hammer and chisel to help remove the bad wood. Small wedges can be used to prop up the board above to enable the bad wood to be removed. Remove the wedges and insert a new piece of clapboard sized to fit the hole. Nail the board in with galvanized nails; putty the seams, sand, prime, and paint.

RESIDENTIAL BUILDINGS:
*Standards and Guidelines for
Rehabilitation and Restoration*



ROOFS

The roof, with its shape; features such as cresting, dormers, weathervanes, cupolas and chimneys; and the size, color and patterning of the roofing material, is important in defining the building's overall architectural character. Historic roofing reflects the availability of materials, levels of construction technology, weather, and cost. Therefore, any changes should take into consideration the following guidelines.

REPAIR

Roofing material shall be retained unless deteriorated. Every effort should be made to retain metal, slate or tile roofs. When partially reroofing, the deteriorated roof shall be replaced with new materials that match the old in composition, size, shape, and texture.

Repair of metal roofs requires knowledge about the interactions between metals, see **Siding-architectural metals**. For example, metals such as tin and copper will react chemically with one another, resulting in galvanic corrosion. In addition, coating of a metal or tin roof with hot tar to stop a leak will hasten the deterioration of the metal.

Repair of slate roofs should be accomplished with copper nails to secure the slate, not iron nails which will rust and allow the slate to become dislodged.

Repair of asbestos shingles should be undertaken with great care as the asbestos dust can be dangerous if inhaled. Complete removal of asbestos shingles requires special handling and disposal. For further information on asbestos hazards and removal, contact the Department of Environmental Quality.

REPLACEMENT

1. The original roof shape or pitch shall not be changed.
2. The configuration of the roof shall not be changed by adding features that were not original to the building such as dormer windows, vents, or chimneys.
3. An application for the removal of a metal, slate, or tile roof is carefully weighed by the Commission. These roofing materials will

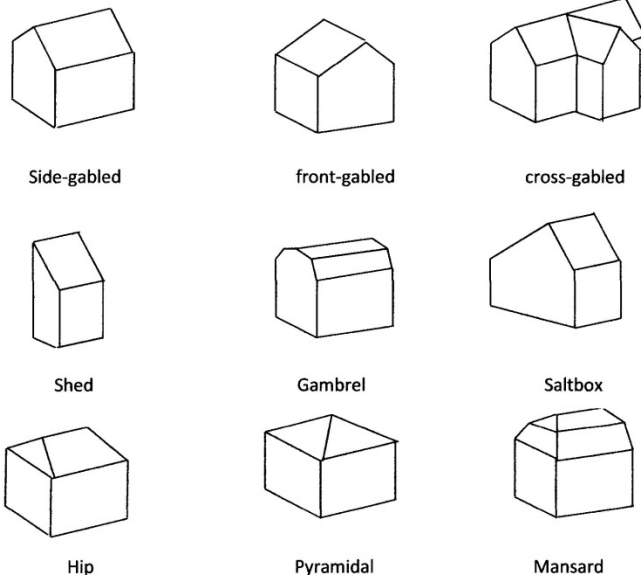

Common Roof Shapes

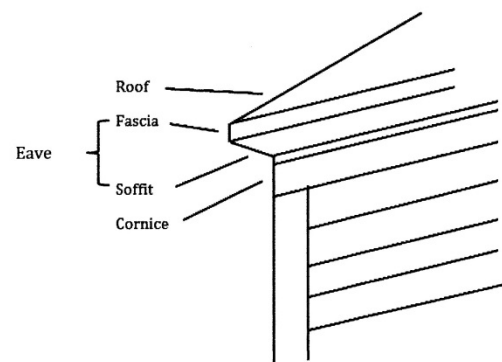

ROOFS

last for well over 100 years and may only need limited replacement and repair as opposed to complete replacement.

4. When entirely reroofing, new materials shall not be used which differ to such an extent from the old in composition, size, shape, color or texture that the appearance is altered. If a new roof color is planned, it should be appropriate to the building and blend in with other buildings on the street.

5. Roll roofing and corrugated metal are not acceptable as replacement roofing materials.

DORMERS AND OTHER DESIGN ELEMENTS

Every effort shall be made to repair and restore character-defining elements such as dormers, vents, cupolas and eave treatments by patching and splicing or by limited replacement with materials matching the original in size, shape, and composition. See **Routine Repair and Maintenance for wood and windows**. These elements shall not be visually altered, covered over, or removed from the building.

If an element is damaged or deteriorated to a point where it cannot be repaired, the replacement shall match the original in design, material, and color. Likewise, if there is evidence that a feature is missing, the feature should be replicated using an existing prototype or using historical, physical or pictorial evidence.

CHIMNEYS

Sometimes if a chimney is not used, the property owner removes or lowers it. Chimneys are important elements of a building's character and shall be repaired and maintained even if they are not in use. For repair of chimneys see **Siding-Masonry**. It is inappropriate to repair a chimney by simply applying a coat of stucco to stabilize the masonry. Stucco should be added only in cases where the existing chimney is stuccoed and needs repair.

If a chimney is deteriorated to such an extent that it must be rebuilt, replacement materials shall be the same in style, composition, color, texture, and strength as the damaged materials. The appropriate mortar composition, color, texture, and application must also be used when rebuilding a chimney. The same bonding pattern and joint width and profile shall be maintained.

A historic chimney shall not be removed. Likewise, a chimney shall not be added when there is no evidence that a chimney existed.

GUTTERS

Historic gutters shall be repaired and maintained where possible. If new gutters must be installed, the half-round type is preferred, but molded gutters are also acceptable. Gutters and downspouts should not be installed in such a way as to remove or conceal significant architectural details. Splash blocks or concealed piping should be installed to provide proper drainage away from the building, so as to avoid water damage to the building.

SKYLIGHTS, SOLAR COLLECTORS, AND MECHANICAL EQUIPMENT

Air conditioning, transformers, solar collectors, and skylights shall be installed so that they are inconspicuous from the public right-of-way, such as on the rear of the building or behind gables or dormers. The installation shall not damage or obscure character-defining features. Skylights should be flat or flush with the roofline, not convex.

SIDING

Siding, in its most basic terms, is the surface material applied to the exterior of a building which provides a permanent barrier against weather. However, siding is much more. The type of siding is important in defining the historic character of the building and its architectural style. It is also often a reflection of the wealth and variety of resources available in an area.

WOOD SIDING

The most frequently occurring siding material in the historic district is wood, whether clapboard, shiplap, flush, or shingles. Wood is a natural insulating material that can last indefinitely if maintained.

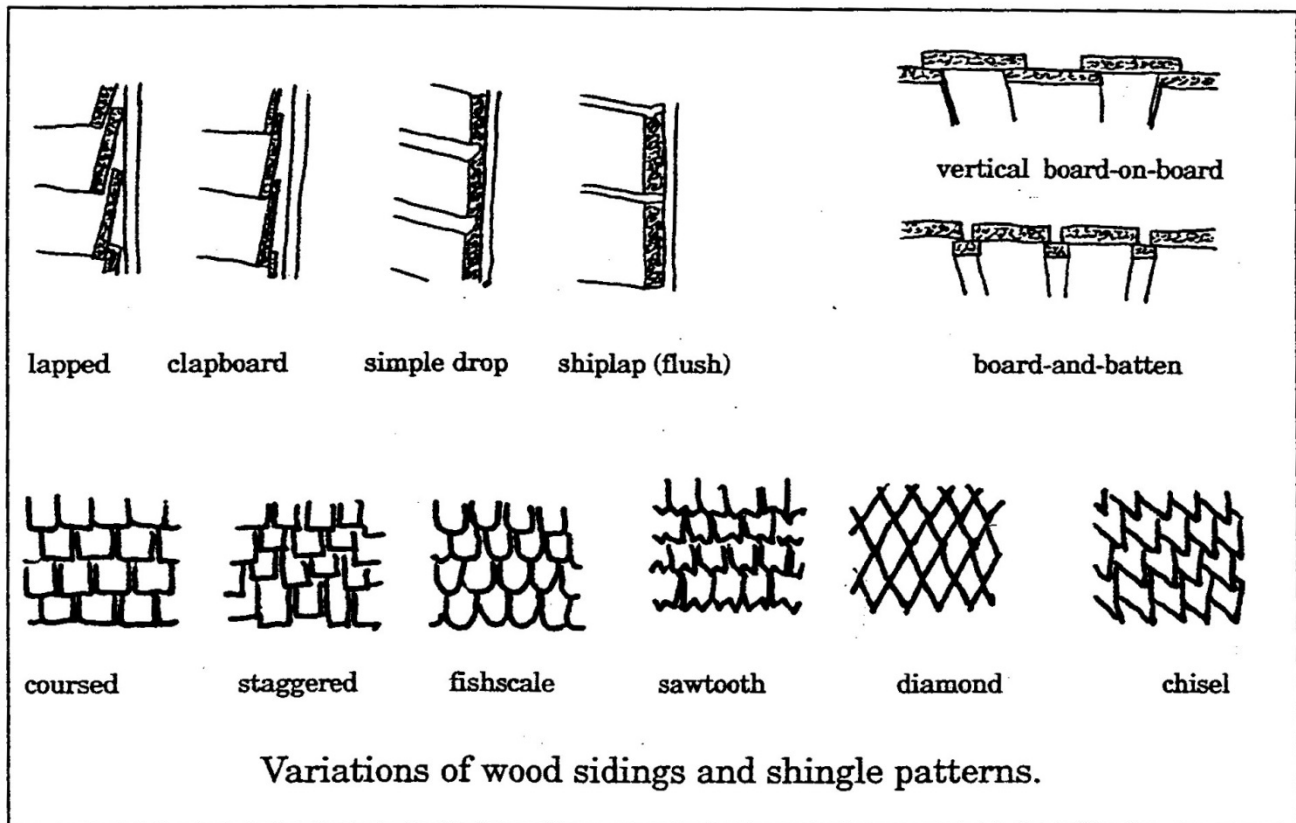

REPAIR

Every effort shall be made to repair wood siding by patching or splicing. See **Routine Repair and Maintenance**.

REPLACEMENT

Where replacement is necessary, the siding shall be replaced with the same materials used in original construction. For example a 6" wood clapboard shall be replaced with a 6" wood clapboard rather than some other material or size. The amount of overlap shall be the same, as well.

CLEANING

The use of destructive paint removal methods such as by propane or butane torch, rotary sanding discs, rotary wire strippers, sandblasting, or waterblasting can irreversibly damage woodwork by eroding the fibers of the wood, pitting the surface, or in the case of torches, by scorching or igniting the wood, and shall not be undertaken. Cleaning of wood siding should be undertaken with natural bristle brushes, detergent and low pressure water. See **Paint** for other information on painting.

MASONRY

Brick, Stone, Terra Cotta, and Concrete

Brick, stone, terra cotta, and concrete are siding materials that are also found in the Brandon Historic District. Early **bricks** were generally composed of clay mixed with silt or sand, which was then pressed into molds and fired in a kiln. In the 1870s the method of producing the brick through an extrusion process made the bricks more uniform and durable. Historic mortars, consisting mainly of lime and sand, were designed to provide flexibility, not rigidity, to a building. The softer historic bricks expand and contract with the weather and the soft mortar allowed this movement. When soft bricks expand and hit hard mortar, the faces of the bricks spall off. Historic mortar has a high lime content which is also slightly soluble in water and is able to self-seal small cracks that may occur. **Stone** is one of the more lasting of masonry building materials. Various types of sandstone, limestone, marble, and granite are found in the district. **Terra cotta**, which came into popularity in the late 19th century, is a kiln-dried clay product which is generally highly decorative. There are a number of buildings in the historic district which exhibit terra cotta panels. Early **concrete** was made of tabby, volcanic ash and later naturally-occurring hydraulic cements. By the turn-of-the-century, Portland cement was used to make precast concrete blocks. Many of these blocks were made to resemble stone blocks and concrete trim was also substituted for sandstone trim.

REPAIR

While masonry is among the most durable of historic building materials, it is also very susceptible to damage by improper maintenance or repair techniques and harsh or abrasive cleaning methods. Every effort shall be made to repair masonry siding by patching or splicing. See **Routine Repair and Maintenance**.

REPLACEMENT

Damaged areas of masonry walls shall be repaired using as much of the original brick or stone as possible. Replacement material shall be the same in style, composition, color, texture, and strength as the damaged materials. The appropriate mortar composition, color, texture and application must also be used when rebuilding a masonry wall. The same bonding pattern and joint width and profile shall be maintained.

REPOINTING MASONRY

Repointing of the mortar joints may be necessary where there is evidence of deterioration such as disintegrating mortar, cracks in mortar joints, loose brick, or damaged plasterwork. Repointing of masonry should only be attempted by professionals who have experience with historic masonry and only after a test panel is completed in an inconspicuous location. The deteriorated mortar should be removed by carefully hand raking the joints back

SIDING

about 3/4". Mechanical tools are not approved for cleaning the joints as they often damage the edges of the brick. The joints are then filled with new mortar that duplicates the historic mortar in strength, composition, color, and texture. As mentioned above, historic mortar is soft in strength because it is high in lime content.

The new mortar shall have the same composition which can generally be achieved by mixing one part lime by volume to two parts sand. In order to match the color of the historic mortar, colored sands or mineral pigmented mortar mixtures can be used. Organic and chemical colorants tend to fade and are not recommended. Finally, the historic mortar joint is duplicated in width and joint profile. Too wide of a profile will create a building where you seem to only see the mortar, not the bricks. Excess mortar should be cleaned off the brick. Only the deteriorated mortar should be removed and repointed. Removing non-deteriorated mortar from sound joints, then repointing the entire building to achieve a uniform appearance is not allowed.

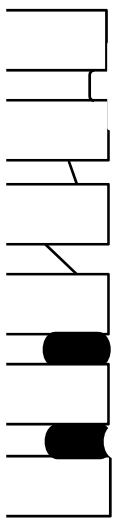

Remove 3/4" of crumbling mortar with hand chisels, being careful not to damage the faces of the brick.

Clean joint, then wet mortar and bricks.

Add new mortar that duplicates the historic mortar in strength, composition, color, and texture.

Match shape of original joint in width and joint profile. It is important to maintain the correct profile. Too wide of a profile will create a building where you seem to see the mortar, not the bricks.

Finally, excess mortar should be cleaned off of the brick.

Method to appropriately repoint masonry.

CLEANING MASONRY

Masonry acquires a patina over time due to weathering and other conditions. This patina is a part of the historic character of the building and should be taken into consideration. Cleaning of masonry should not be considered if the purpose is to give the building a new and uniform look. Masonry shall be cleaned only when necessary to halt deterioration or remove heavy soiling. Further, cleaning shall take place only after masonry surface cleaning tests. Tests should be observed over a sufficient period of time so that both the immediate effects and the long term effects are known to enable selection of the gentlest method possible, such as low pressure water (not to exceed 600psi) and detergents and natural bristle brushes. The use of high pressure water to clean masonry will damage original masonry and mortar joints and shall not be used. Cleaning with chemical products generally damages masonry or leaves a residue on the masonry and is not permitted unless the product is approved by the Mississippi Department of Archives and History, Historic Preservation Division.

WATERPROOF COATINGS

Waterproof coatings are not recommended for historic brick surfaces because they trap moisture which causes spalling of the surface. Bricks are designed to pass moisture from the inside surface to the exterior, therefore using a waterproof sealer will cause moisture problems on the interior surfaces as well. If it is believed that a coating is necessary, a breathable product may be approved by the Commission once it is approved by the Mississippi Department of Archives and History, Historic Preservation Division.

PAINTING

Masonry which has never been painted shall not be painted. On a case by case basis, the Commission may approve a historically unpainted brick building to be painted if the brick and mortar are extremely mismatched from earlier repairs and repointing. However, if the earlier mortar repairs are the wrong color, but the brick is correct, the Commission may approve the painting only of the mortar joints to match the historic mortar color of the rest of the building.

STUCCO

Stucco was historically added to a building as a part of the architectural style or as protection against moisture. Therefore, stucco shall not be removed from a building.

REPAIR AND REPLACEMENT

Early stucco coatings were lime-based and were soft enough that the bricks that they covered could expand and contract. Hard stucco placed over soft bricks will cause the brick to spall taking the stucco with it. Stucco repair must match the original in strength, composition, color and texture. A test panel should be completed before patching stuccoed walls.

CLEANING

Stucco acquires a patina over time due to weathering and other conditions. This patina is a part of the historic character of the building and should be taken into consideration during rehabilitation. Cleaning of stucco should not be considered if the purpose is to give the building a new and uniform look. Stucco shall be cleaned only when necessary to halt deterioration or remove heavy soiling. Further, cleaning shall take place only after stucco surface cleaning tests. Tests should be observed over a sufficient period of time so that both the immediate effects and the long term effects are known in order to determine the selection of the gentlest method possible, such as low pressure water (not to exceed 100psi) and detergents and natural bristle brushes. The use of high pressure water to clean stucco will damage original materials and shall not be used. Cleaning with chemical products generally damages stucco or leaves a residue on the masonry and is not permitted unless the product is approved by the Mississippi Department of Archives and History, Historic Preservation Division.

WATERPROOF COATINGS

Waterproof coatings are not recommended for historic stucco surfaces because they trap moisture which causes spalling of the surface. Using a waterproof sealer will cause moisture problems on the interior surfaces as well. If it is believed that a coating is necessary, a breathable product may be approved by the Commission upon review by the Mississippi Department of Archives and History, Historic Preservation Division.

PAINTING

Stucco which has never been painted shall not be painted. On a case by case basis, the Commission may approve a historically unpainted stuccoed building to be painted if the surface is defaced from earlier repairs.

ARCHITECTURAL METALS

Architectural metal features and siding are important in defining the overall character of a building. Metals commonly used in historic buildings include lead, tin, zinc, copper, bronze, brass, iron, steel, and to a lesser extent, nickel alloys, stainless steel and aluminum. Historic metal building components were often created by highly skilled, local artisans, and by the late 19th century, many of these components were prefabricated and readily available from catalogs in standardized sizes and designs.

REPAIR

Every effort shall be made to repair historic metal siding by patching or splicing. See **Routine Repair**.

REPLACEMENT

If metal siding must be replaced, the replacement materials shall be the same in style, composition, color and texture as the damaged materials. Care should be taken to assure that the replacement pieces are attached to the building by the correct means. Removing a major portion of the historic architectural metal instead of repairing and replacing the deteriorated metal in order to create a uniform or improved appearance is not allowed. If the metal siding is missing, the replacement siding shall be based on historical, pictorial, and physical documentation.

CLEANING

Metals shall be cleaned only to remove corrosion prior to repainting or applying other appropriate protective coatings, not to create a “new” look. Often the metal has acquired a patina which may be a protective coating on some metals, such as bronze or copper, as well as a significant historic finish. The following issues shall be addressed prior to cleaning of historic metals:

- A. Identify the particular type of metal prior to any cleaning procedure.
- B. Test to assure that the gentlest cleaning method possible is selected.

Cleaning soft metals such as lead, tin, copper, tern plate, and zinc should be with appropriate chemical methods because their finishes can be abraded by blasting or other abrasive means.

PAINTING

Some metals such as copper, bronze, or stainless steel were often meant to be exposed (unpainted) and shall not be painted if historically not covered. Likewise, those metals that were historically painted are to remain painted.

OTHER CONSIDERATIONS

Incompatible metals shall not be placed together without providing a reliable separation material. Such incompatibility can result in galvanic corrosion of the less noble metal. For example, copper will corrode cast iron, steel, tin, and aluminum.

SYNTHETIC SIDING

Homeowners are often attracted to synthetic sidings such as vinyl, aluminum, EIFS (synthetic stucco), Masonite, and imitation brick siding because of manufacturer's claims that the material will keep exterior moisture from entering the building and that the siding will not have to be repainted every 5-10 years. While there might be some perceived advantages to synthetic sidings, there are some major disadvantages. The application of synthetic siding to historic buildings in the Brandon Historic District shall not be approved for the following reasons:

1. The synthetic siding conceals the historic siding and character, lowering the integrity of the historic building itself and the historic district as a whole. Synthetic siding creates a different profile, surface level, and appearance than the existing siding. Placing new siding over existing siding causes recessed areas to appear deeper and projecting surfaces to appear shallower, thus dramatically altering the building's appearance. In addition, during installation historic elements are often removed to make it easier to apply the siding. The removal of any ornamental details diminishes the character of the building.
2. Synthetic siding does not allow moisture to pass through it and therefore, moisture can get trapped behind the siding, accelerating the deterioration of the wood siding. Historic wood siding was intended to breathe and pass moisture from the interior of the structure to the exterior. Synthetic sidings do not allow this moisture to exit to the outside and consequently the moisture is trapped and the wood deteriorates.
3. In addition, the lifetime of synthetic sidings is unknown. Manufacturers claim some of the sidings will last to 30 years. During this time, because the wood siding is unmonitored and inaccessible, it is very likely that it will deteriorate, to the point that structural problems may threaten the integrity of the building.

OTHER CONSIDERATIONS

The factory applied finish of the vinyl and most other synthetic sidings will deteriorate over time, due to exposure to the environment and to ultra violet light. When these finishes have deteriorated significantly, they will have to be painted, just as the wood siding that it covered would have had to be. In addition, synthetic siding materials typically cannot withstand impact damage as well as wood; a damaging hailstorm has been known to leave a synthetic-sided building heavily dimpled. With constantly changing technologies, synthetic siding materials often go out of fashion or the technology is replaced by other technologies. Finding replacement parts of cladding systems as they get older can be time consuming and costly and may not match the color of the rest of the building, making it necessary to paint the entire building. It is difficult to find a paint that will adhere for any length of time.

The addition of synthetic siding can detract from a building's resale value because it may be believed that the siding was installed to hide structural problems. Potential purchasers may find it difficult to fully inspect the building for potential problems because the siding cannot be easily removed.

The Commission will consider case by case the use of "hardi-plank siding" and other concrete siding materials.

ARCHITECTURAL ORNAMENTATION

Architectural ornamentation represents some of the most important stylistic elements on a building and gives the building a distinctive appearance. Architectural detailing includes a wide range of features such as brackets, window and door hoods, vergeboards, dentils, cornices, molding, shingles, and pilasters. It also includes features such as finials, cresting, corbelling and columns. These details are most often made of wood and are easily damaged; therefore extreme care should be taken to ensure that ornamentation is repaired and retained. Ornamentation adds to the character of a building and enhances its value.

REPAIR

Original detailing shall be retained and repaired. Every effort shall be made to repair features by patching or piecing-in using recognized preservation methods. See **Routine Repair and Maintenance and the rehabilitation sections on wood siding; masonry** for corbelling or terra cotta; and **architectural metals** for metal cresting and finials.

REPLACEMENT

If an element is damaged or deteriorated to a point where it cannot be repaired, the replacement shall match the original in design, material and color. Likewise, if there is evidence that a feature is missing, the feature should be replicated using an existing prototype or using historical, physical or pictorial evidence.

REMOVAL OF DETAILS

No architectural features that are original to the building shall be removed. Damaged details must be repaired and replaced.

NEW DETAILS

Architectural features shall not be added to an existing building unless there is photographic evidence that the features originally existed.

PORCHES AND BALCONIES

Porches in Brandon range from small Greek Revival porticos, just enough room to be protected from the rain, to full-width, two tiered, front galleries that provided an additional room to escape to on a hot day, even a couple of homes with wrap-around porches. Front porches are the dominant feature on most residential buildings and often exhibit the most architectural detail. They add scale to the building and, as they generally appear on every building along the street, contribute significantly to the rhythm and character of the neighborhood.

REPAIR

Every effort shall be made to repair porches and balconies and their details by patching, splicing, consolidating or otherwise reinforcing deteriorated sections. See **Routine Repair and Maintenance**.

REPLACEMENT

Where replacement of a porch or its details is necessary, it shall be replaced with the same materials used in original construction to match the original in design, scale and placement. See **Architectural Ornamentation**. If a detail that is to be replaced is found to be non-historic, the replacement detail shall be designed to match the original feature of the porch or balcony. For example, if round wooden columns are replaced with wrought iron columns in the 1970s and these columns are now to be replaced, they should be replaced with round wooden columns that match the historic columns that once existed on the porch or balcony.



Original columns.

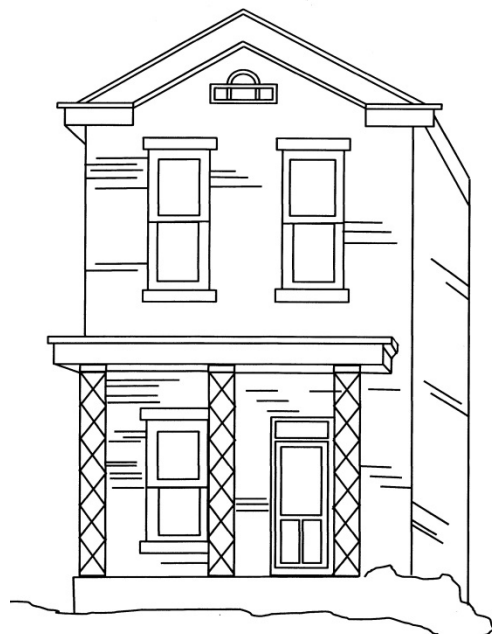

Inappropriate replacement columns.

PORCHES AND BALCONIES

REPLACING MISSING OR MODERNIZED FEATURES

If the original porch is missing or has been modernized to a point where it is difficult to distinguish the historic appearance, the porch may be replaced using photographic documentation to design the new porch. If there is no documentation, the new porch should be designed in wood and in keeping with the architectural style of the building. The new design should take into consideration porches of other buildings of the same age and style in the neighborhood. Ornamentation that is incompatible with the style of the house shall not be included in the new design.

REMOVING A PORCH OR PORCH FEATURES

A porch that is historically a part of a building shall not be removed for any reason and not be replaced. The replaced porch shall convey the same visual appearance as the removed porch. In addition, porch components that are removed for any reason must be replaced and must match the original in design, material, size and style. Components cannot be removed and not be replaced.

ADDING DETAILS

Undocumented historic details shall not be added to a porch as they convey a false sense of history.

ADDING RAILINGS

Some historic residences in Brandon were constructed without balustrades on the front porch. Where code requirements or modern use require railings on the porch, the balustrade should be designed in materials in keeping with the period and style of the building. Generally a balustrade made up of square wooden balustrades which are 3' high and 2" in width and depth will be appropriate.

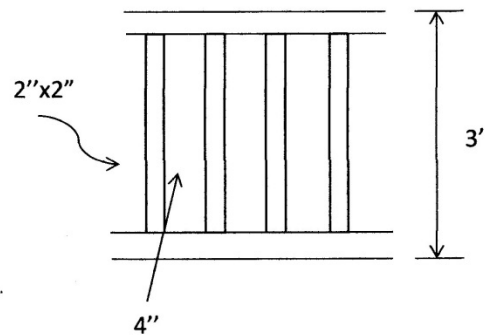

SCREENING

Enclosing a porch with screen is allowable in the Brandon Historic District if the following standards are met:

1. The screen is placed behind the columns and balustrade.
2. The framing system is a simple design which is painted to match the color of the columns or trim with as few

vertical and horizontal divisions as possible.

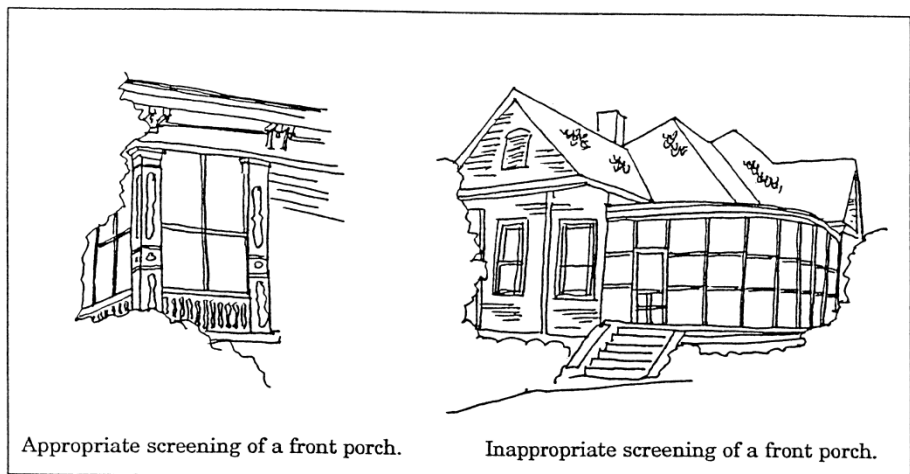

PORCHES AND BALCONIES

3. The screen should fit from framing member to framing member without any infill material between the screen and the member.
4. New screen doors which enter the screened porch should be full-view, wood, and painted the color of the framing. In addition, the screen door must fit the opening. Installation that requires blocking in to make the door fit is not acceptable.

FLOORS

The existing porch flooring material shall be repaired by patching and splicing or by limited replacement with materials matching the original in size, shape, composition, and color. If replacement is necessary because of advanced deterioration, the replacement shall match the original. Removal of a wood porch deck and replacement with concrete shall not be permitted.

PORCH FOUNDATIONS

See **Foundations**.

PORCH ROOFS

See **Roofs**.

ENCLOSING A FRONT PORCH ANYWHERE OR A SIDE PORCH IF FACING A STREET

In some instances, it may be desirable to enclose a porch to accommodate additional living space. Such enclosures can be designed in a manner that preserves the historic character of the building, while providing for the requirements of additional living space. If enclosing a front porch or a wrap-around porch or if enclosing a side porch if the porch faces a street, such as in the case of a corner lot, the following standards must be met:

1. Porches may be enclosed with the use of large sheets of glass that are recessed behind the existing posts, columns and balustrade.
2. The framing system to support such glass panels must be simple and unobtrusive and designed with as few vertical and horizontal divisions as is possible.
3. The glass panels should fit from framing member to framing member without any infill material between the glass.
4. The glass shall be clear, not tinted or etched.

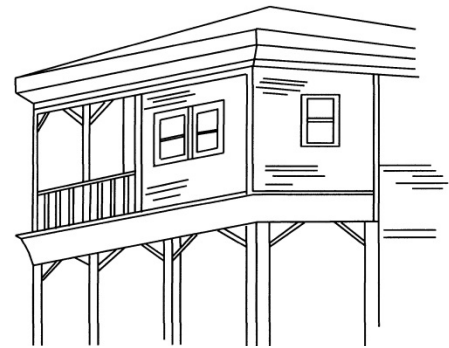

Inappropriate enclosing of a second-floor front porch

PORCHES AND BALCONIES

5. The door into this enclosure should also be of a single sheet of glass.
6. The original windows and door of the house should still be visible to the outside, thereby maintaining the character-defining elements of the building.
7. The framing system should be painted the house body color.

ENCLOSING A REAR OR SIDE PORCH

Rear or side porches (that are not located on a corner lot) may be enclosed for additional living spaces if they are not readily seen from the public right-of-way if they meet the following standards:

1. If the porch is significant to the character of the building and if the enclosure of the porch impacts the front elevation of the house, the porch may be enclosed as described above in the front porch standards.
2. If it is deemed that the rear or side porch is not seen from the public right of way, it may be enclosed using the same material as the house is covered with. For example, if the house is sided with clapboard, the porch, if not enclosed with glass, should be enclosed with clapboard. The only exception to this is that the porches of brick or stone residences may be enclosed with clapboard or with the existing material of the house.

NEW PORCHES

1. If there is no evidence that a front porch existed, a new front porch shall not be approved.
2. If there is no evidence that a rear porch existed and if the rear is hidden from the public right of way, a rear porch may be added. The design must be compatible in design, scale, size and materials with the building and should meet the following standards:
 - a. New rear porches should not be any wider than the width of the existing building.
 - b. The roof shall be no higher than that of the existing building and the roof form should be compatible with that of the existing building.
 - c. The foundation height, floor and eave lines of the porch should line up with those in the existing building.
 - d. Ornamentation shall not be more elaborate on the new porch than on the existing building.

STEPS AND RAILINGS

REPAIR

Every effort shall be made to repair steps and railings by patching and splicing or by limited replacement with materials matching the original in size, shape, and composition. See **Routine Repair and Maintenance**.

REPLACEMENT

When replacement of step components or railings is necessary, the replacement materials shall match the original in design, scale and placement.

REMOVING STEPS

Steps and railings that are historically a part of a building shall not be removed for any reason and not be replaced. The replaced steps and railing shall convey the same visual appearance as those removed (see **replacement** above).

NEW STEPS

If the original steps and/or railings are missing or have been modernized to a point where it is difficult to distinguish the historic appearance, the steps and railings may be replaced using photographic documentation to design the new ones. If there is no documentation, the new steps and railings should be designed in wood and in keeping with the architectural style of the building. The new design should take into consideration steps and railings of other buildings of the same age and style in the neighborhood. Ornamentation that is incompatible with the style of the house shall not be included in the new design.

New steps shall not be precast or pre-manufactured concrete or metal.

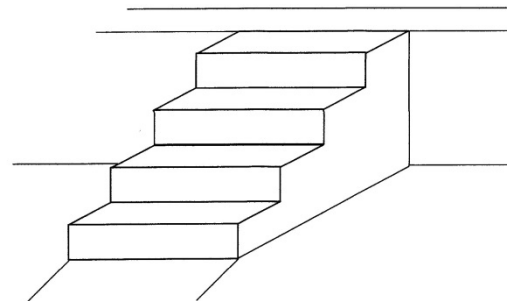

Inappropriate precast concrete steps

NEW RAILINGS

In cases where a railing was never designed for the building, but code requirements or new uses require a railing on the stairs, the new railing design shall take into consideration the style of the building and be compatible with it. New railings shall not be wrought or decorative iron where there is no historic evidence for such.

NEW GATES

In cases where porch gates were never designed for the building, but code requirements or new uses require them on a raised porch, the design of the new gates shall match the design of the railings on the house and stairs.

FOUNDATIONS AND CRAWL SPACES

Most residential buildings within the Brandon Historic District were built raised on brick piers or brick walls. The purpose of this type of construction was to keep the wooden sills and floor joists away from the damp ground and to provide ventilation for heat and moisture. One of the most common rehabilitation projects is to enclose the foundation to keep animals from inhabiting the area and to assist in energy conservation.

REPAIR

Foundation piers and crawl space enclosures shall be maintained and preserved. Every effort shall be made to repair brick piers by patching or splicing. See **Routine Repair and Maintenance** and **Masonry**-replacement, repointing, cleaning, waterproof coatings and painting.

REPLACEMENT

Where replacement of a pier is necessary, the piers shall be replaced with the same materials used in the original construction. See **Masonry**-replacing.

INFILL BETWEEN PIERS

1. Infill can be brick lattice, solid brick with vents (spaces left within the brick wall to allow or air to flow), or wood lattice (painted the color of the siding). Plywood which is painted black or black roofing paper can be attached to the back of the lattice panels in order to reduce air infiltration. However, vents should still be maintained in the plywood or roofing paper to allow for air to flow under the building.

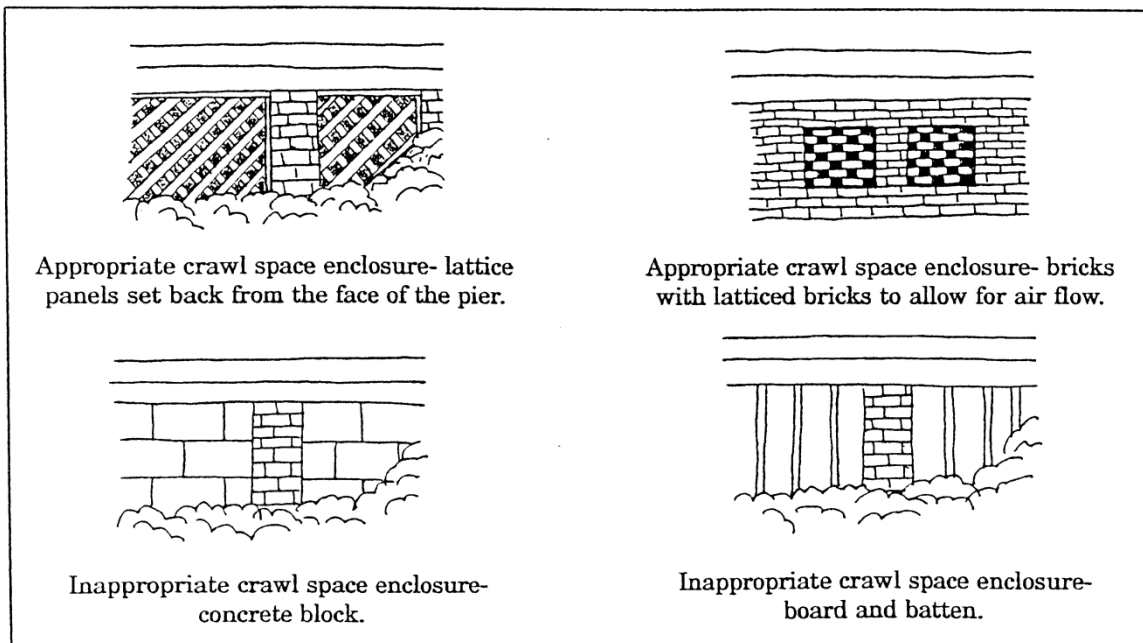

2. Plywood panels, metal, board and batten and concrete block are not appropriate.

3. Infill shall be set back from the face of the piers so that the piers are easily visible, the infill shall not be flush with the face of the piers.

4. The under-skirting shall not cover over the piers.

WINDOWS

Windows and their decorative features (such as frames, sash, muntins, mullions, sills, heads, hoodmolds, jambs and moldings) are important in defining the historic character of a building. Changes that alter the appearance of the sash, depth of reveal or muntin configuration: the reflectivity and color of the glass; or the appearance of the frame through the use of inappropriate design, materials, finishes, or colors diminish the historic character of the building.

Windows are one of the most important character defining features of a building for two main reasons. They comprise a considerable amount of the historic fabric of the wall and provide the rhythm and balance of the façade. The window is also one of only two elements (the other being the door) of a building that serves as both an interior and exterior feature. Therefore, the integrity of the original windows and window surrounds should be preserved through the use of the following guidelines:

REPAIR

Every effort shall be made to repair and restore windows and their decorative features by patching and splicing or by limited replacement with materials matching the original in size, shape, and composition. See **Routine Repair and Maintenance**.

REPLACEMENT

1. Repair of historic windows should always be considered before replacement; then selective window replacement is recommended over complete replacement of all windows. Windows are very important in determining the character of a building and therefore replacement of historic windows must be made carefully. Replacement windows that are placed incorrectly, sized differently than the original windows, constructed of different materials, or have a different configuration of window panes will completely change the character of a building.

2. If replacement is necessary because of advanced deterioration, the replacement window shall match the original window with regard to the following standards:

- A. Design – for example, double hung windows should be replaced with double hung windows.
- B. Materials – constructed of the same materials (i.e. wood windows should be replaced with wood windows)
- C. Size – the window opening shall not be blocked down or made larger.
- D. Placement – replacement windows shall be placed in the original location.

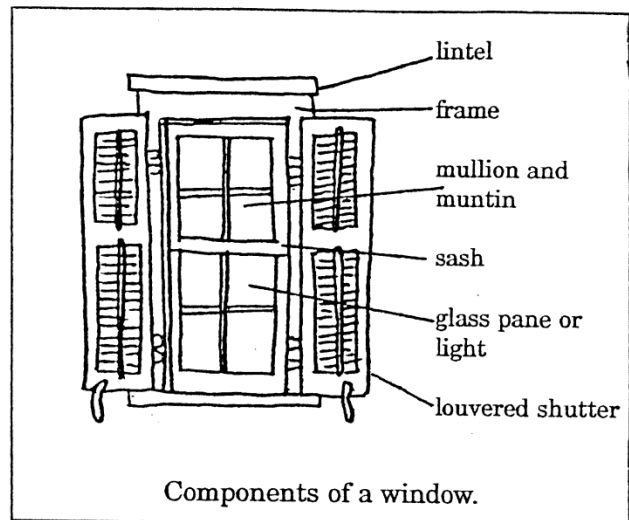

WINDOWS

E. Configuration of window panes (the replacement shall have the same size, number, and placement of window panes).

F. Characteristics of the glass – clear glass shall be replaced only with clear glass, etc.

G. Snap-in muntins, which simulate the subdivision between the lights shall not be used. Only true divided light sash shall be used because snap-ins alter the historic appearance of the building because they lack the depth and profile of historic windows.

H. Depth of reveal (the distance between the front of the wall and the window) of the replacement windows shall be the same as the depth of the original window.

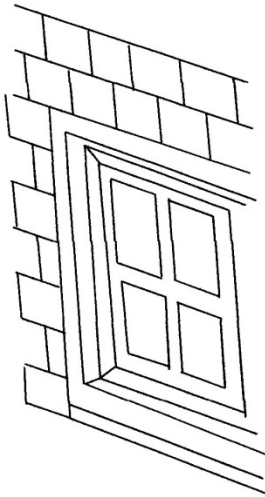

Window reveal- the setback of the window from the face of the wall.

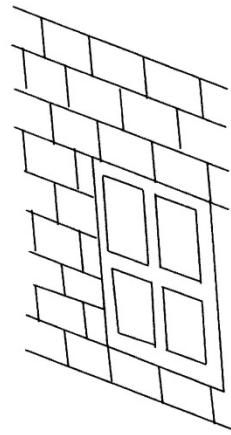

A window that is flush with the wall. There is no reveal.

3. If a non-historic window is to be replaced with one that is more in keeping with the original window, the replacement window shall be an accurate restoration using historic, pictorial, and physical documentation. Where this information is not available, a new design shall be used that is compatible with the window openings and the historic character of the building.

4. Vinyl-clad wood windows, single or double glazed, with true or simulated divided lights, may be acceptable replacement windows for those that are not in the public view, such as on the sides (not a corner building) or back of a building, if the windows match the original configuration and profiles. The depth of reveal must be maintained. Raw aluminum, bronze-colored aluminum, and painted aluminum or vinyl-clad windows that do not have true divided lights are not acceptable replacement windows.

NEW WINDOW OPENINGS

New window openings shall not be created on the fronts or sides of buildings. On a case by case basis the Commission may consider new windows on the rear of a building or into an exposed party wall. Such design

WINDOWS

should be compatible with the overall design of the building, but not necessarily duplicate the fenestration pattern and detailing of a character-defining elevation.

REMOVAL OF WINDOWS

Historic window openings and their sashes shall not be removed, and the openings covered over because this significantly changes the character of the building.



Original windows on the second floor.



Inappropriately blocked-up windows.

WHEN INTERIOR CHANGES AFFECT THE EXTERIOR

If it is necessary to drop a ceiling for a new interior use, there shall be a set-back in the design to allow for the full height of the window opening so that the ceiling does not cut across the window.

WINDOW SURROUNDS

Original decorative features, such as crown molding, entablatures, and pilasters that comprise a window surround, shall be preserved and maintained. These features shall be repaired by patching and splicing or by limited replacement with materials matching the original in size, shape, and composition.

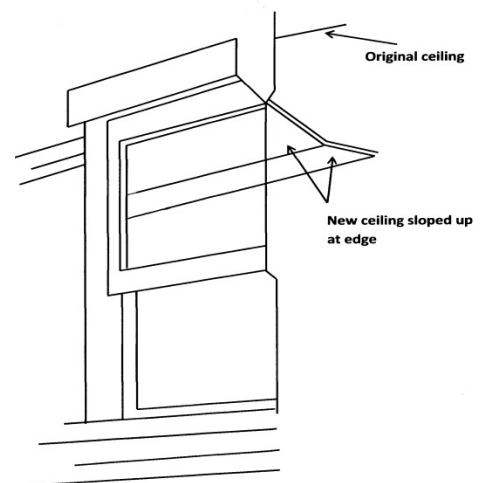

WINDOWS

Window surrounds that are original to the building shall not be removed.

If replacement of a feature is required because of advanced deterioration, the replacement feature shall match the original feature with regard to design, materials, size, placement, and color.

Window surrounds shall not be added to historic buildings unless based on documentation and then shall conform strictly to historic appearance and materials.

WINDOW COATINGS

Tinting, reflective coatings and opaque window coverings on historic windows are not allowed as they change the look of the historic glass. However, to protect interior fabrics from ultraviolet rays, clear adhesive filtering film designed to reduce the destructive effects of ultraviolet light can be applied to the interior surface of the windows.

STAINED GLASS WINDOWS

Stained glass windows can be protected from accidental or intentional damage by the installation of glass or plastic panels placed over the windows, if the following standards are met:

1. The supports for the protective panels shall align with the mullions of the window.
2. Panels should have adequate ventilation at the top and bottom to allow for air circulation so that moisture does not build up and cause deterioration of the sash.

STORM WINDOWS

Storm windows should be installed on the interior of the window so that the appearance of the historic window is not changed. There are several kinds of interior storm windows including those that attach to interior frames with magnets, Velcro, screws or clips. While interior storm windows are preferable, exterior storm windows are allowed in the Brandon Historic District if they blend in with the building and take into consideration the following standards:

1. Care should be taken when installing storm windows to ensure that the original windows and window features are not destroyed or obscured.

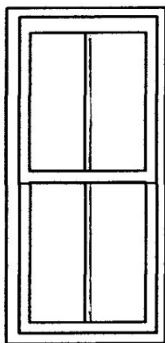

Window to which the storm window will be attached.

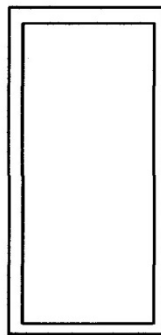

Exterior storm windows should be full view or sectioned so that the meeting rail meets the rail of the existing window.

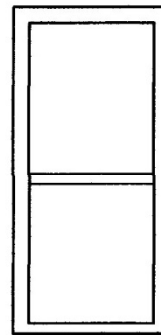

WINDOWS

2. The shape and general appearance shall match the existing window as closely as possible to being full view (single sheet of glass) or sectioned in an unobtrusive manner so as not to obscure or distort the existing window. The meeting rail of the storm window shall align with the meeting rail of the window to which it is applied.
3. Storm windows shall be made of wood, baked enamel, or metal painted to match the window trim. Raw metal or bronze-colored storm windows are not acceptable.
4. The glass shall be clear, not tinted.
5. Storm windows should have adequate ventilation so that moisture is allowed to escape and does not build up and cause deterioration of the sash.
6. Exterior track storm windows are not acceptable because they obscure historic detailing of the window and generally jut out beyond the wall surface.

SHUTTERS

Shutters that are original to a building should be preserved and maintained. If repairs are necessary they shall be repaired by patching and splicing or by limited replacement with materials matching the original in size, shape, and composition. If replacement of a shutter is required because of its advanced deterioration, the replacement shutter shall match the original feature with regard to design, materials, size, placement, and color. Other standards for shutters are as follows:

1. Shutters shall not be added to buildings unless there is evidence that shutters were original to the building.
2. Replicated shutters shall be of wood (vinyl, aluminum or other materials are not appropriate because they do not reflect the character of wood and are incompatible with the materials of historic buildings).
3. Shutters must fit the window opening so that when closed they cover the window opening.
4. Shutters should be affixed to the inside of the window frame (not the siding) with shutter hinge hardware.
5. Deteriorated shutters that cannot be repaired should be used for spare parts to repair other shutters on the building.

SECURITY BARS

Exterior security bars are inappropriate in the Brandon Historic District because they change the historic appearance of the window. In addition, bars tend to give a negative impression of the neighborhood. If bars are necessary, they should be of a simple, not decorative design and be placed on the interior and preferably only on the side and rear elevations.

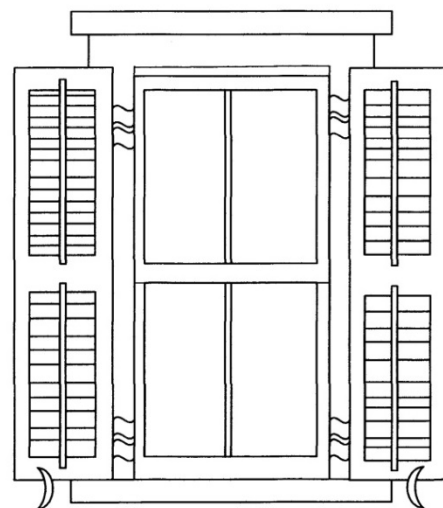

Fasten to window, not to siding. Sized to fully cover the window.
Correct shutter installation.

DOORS

Doors and their surrounds (such as sidelights, transoms, fanlights, entablatures, pediments and pilasters) are important in defining the historic character of a building. Changing the historic appearance of doors through the use of inappropriate design, materials, finishes, or colors diminishes the character of the building and is therefore not permitted.

REPAIR

Every effort shall be made to repair and restore doors and their decorative features by patching and splicing or by limited replacement with materials matching the original in size, shape, and composition. Deteriorated doors can be refinished, cracks and holes can be filled, hinges can be repaired, and rotten frames can be repaired or replaced. In addition, original hardware shall be repaired and retained. See Routine Repair and Maintenance.

REPLACEMENT

1. Repair of historic doors should always be considered before replacement, but if replacement is necessary because of advanced deterioration, the replacement door shall match the original with regard to the following standards.

- A. Design – for example, double doors should not be replaced with a single door, or a six-panel door should not be replaced with a four-panel.
- B. Materials – constructed of the same materials (i.e. wood door shall be replaced with a wood door).
- C. Size – the door opening shall not be blocked-down or made larger
- D. Placement – the replacement door shall be placed in the same opening as the original door.
- E. If the door is glazed (has a window in it) the following standards shall be met:
 1. Configuration of the window panes- shall have the same size and number.
 2. Characteristics of the glass-clear glass shall be replaced only with clear glass, etc.
 3. Snap-in muntins, which simulate the subdivision between the lights, shall not be used. Only true divided light sash shall be used because snap-ins alter the historic appearance of the building because they lack the depth and profile of historic windows.

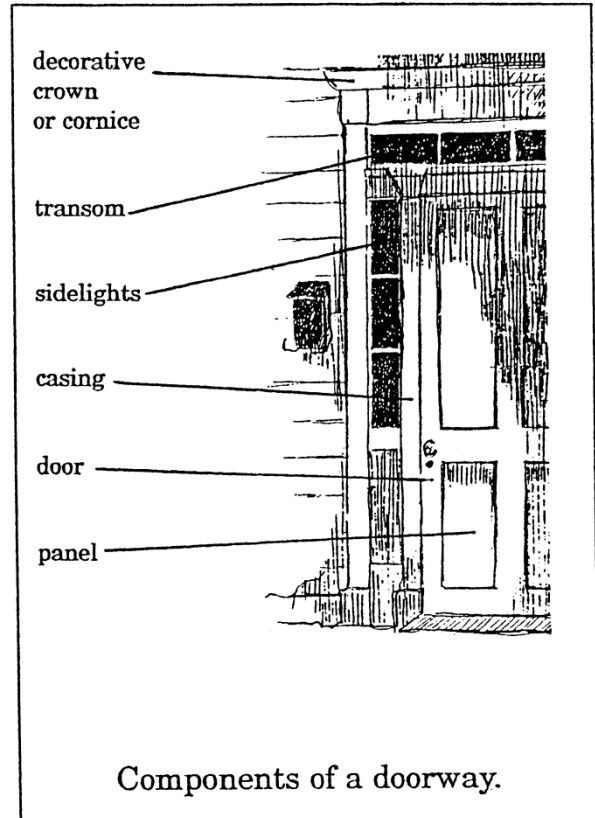

DOORS

F. Depth of reveal (the distance between the front of the wall and the door)-of the replacement door shall be the same as the original door reveal.

G. Hardware from the original door should be used on the replacement door.

2. If a non-historic door is to be replaced with one that is more in keeping with the original door, the replacement shall be an accurate restoration using historical, pictorial, and physical documentation, or where this information is not available, be a design that is compatible with the door opening and the historic character of the building.

NEW DOOR OPENINGS

New door opening shall not be created on the fronts or sides of buildings. On a case-by-case basis the Commission may consider new doors on the rear of a building or into an exposed party wall. Such new door design shall be compatible with the overall design of the building, but not necessarily duplicate the detailing of a door on a character-defining elevation.

REMOVAL OF DOORS

Historic doors shall not be removed, and the opening covered over.

DOOR SURROUNDS

Original decorative features, such as fanlights, sidelights, transoms, crown moldings, pediments, entablatures and pilasters which comprise a door surround, shall be preserved and maintained. The following standards shall be followed:

1. These features shall be repaired by patching and splicing or by limited replacement with materials matching the original in size, shape, and composition.
2. Door surrounds that are original to the building shall not be removed.
3. If replacement of a feature is required because of its advanced deterioration, the replacement feature shall match the original feature with regard to design, materials, size, placement, and color.
4. If fanlights, sidelights or transoms need to be replaced, the replacement shall match the original glazing with respect to the following:
 - A. Configuration of window panes (size, number and location)
 - B. Characteristics of the glass – clear glass shall be replaced only with clear glass, etc.
 - C. Snap-in mullions shall not be used.
 - D. Depth of reveal of the replacement shall be the same as the original.

WINDOW COATINGS ON GLAZED DOORS

Tinting, reflective coatings and opaque window coverings on historic glazed doors are not allowed as they change the look of the historic glass. However, to protect interior fabrics from ultraviolet rays, clear adhesive filtering

DOORS

film that is designed to reduce the destructive effects of ultraviolet light can be applied to the interior surface of the windows.

STAINED GLASS WINDOWS IN DOORS

Stained glass windows in doors, transoms, sidelights or fanlights can be protected from accidental or intentional damage by the installation of glass or plastic panels placed over the windows, if the following standards are met:

- A. The supports for the protective panels shall align with the mullions of the window.
- B. Panels should have adequate ventilation at the top and bottom to allow for air circulation so that moisture does not build up and cause deterioration of the sash.

STORM DOORS

Storm doors should not be installed on front doors, except as provided for below, because they change the appearance of the historic door. They are more appropriate for the rear and side entrances. Storm doors are allowed in the Brandon Historic District if they blend in with the building and take into consideration the following standards:

- A. Care should be taken when installing storm doors to ensure that original doors and door features are not destroyed or obscured.
- B. The shape and general appearance shall match the existing door as closely as possible by being full view (single sheet of glass) or sectioned in an unobtrusive manner so as not to obscure or distort the existing door. Ornate or decorative grillwork or doors with extensive structural framework are not allowed.
- C. Storm doors shall be made of wood, baked enamel, or metal painted to match the door trim. Raw metal or bronze-colored storm doors are not acceptable.
- D. The glass shall be clear, not tinted.

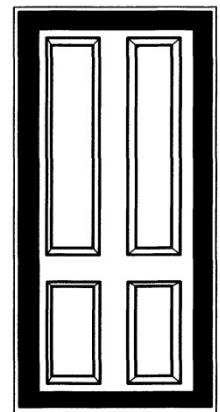

Appropriate full-view storm door.

SECURITY DOORS

Exterior security doors are inappropriate in the Brandon Historic District because they change the historic appearance of the door. In addition, they tend to give a negative impression of the neighborhood. If security doors are necessary, they should be of a simple, not decorative design and should be placed on the interior, preferably on the side and rear elevations. They should fit the opening and not require blocking down of the door frame.

SCREEN DOORS

Original screen doors should be preserved and maintained. New screen doors should be wood, painted the color of the door, full-view or with structural members aligned with those of the original door so as not to obscure the historic door. In addition, the screen door must fit the door opening. Installation that requires blocking in the door frame to make the screen door fit is not acceptable.

AWNINGS

Awnings are used to reduce the effects of the sun and rain on the interior of a building. The historic design of awnings can also add to the character of a building's façade.

APPROPRIATE AWNINGS AND INSTALLATION

1. Canvas, vinyl-coated, or acrylic awnings are appropriate for the late and post Victorian buildings within the Brandon Historic District.

2. Awnings should be installed to fit inside the window trim and should cover only one window, not span a distance to another window. They should fit the opening, rectangular windows should have shed type awnings, while rounded windows should have curved awnings.

3. The color of the awning should complement the building and its neighbors. The color and pattern should not detract from the appearance of the building or street.

4. Awnings should not be installed over windows which have shutters.

5. Awnings should not cover or conceal significant architectural details.

6. Wooden awnings are appropriate for some styles of buildings and will be approved on a case by case basis.

7. Metal slat, rigid plastic, aluminum, cedar or plastic shakes, and brightly colored or glossy awnings are not appropriate in the Brandon Historic District and are not permitted.

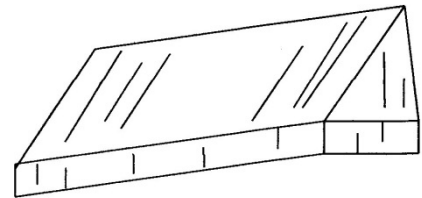

An appropriate awning.

The Commission does not approve paint color choices. However, the Brandon Design Guidelines provide basic painting information to the homeowner. Choosing the colors to paint a building is one of the most challenging decisions that a property owner can make. One person's idea of a beautiful color combination may appear dull and boring or conversely, extravagant and loud to another person. Regardless of the color of paint, property owners should follow the cleaning and surface preparation guidelines below to ensure a lasting paint finish.

CLEANING AND SURFACE PREPARATION

The main reason that a paint finish does not last as long as the manufacturer's guarantee is that the surface was not properly prepared prior to painting. Paint will only adhere to a clean, dull, sealed surface. Problems such as peeling, checking and flaking occur when the surface has not been adequately prepared and moisture works its way behind the paint film and forces the paint from the substrate. Moisture can also cause mildew to grow which eats protein and nutrients contained in paints.

Prior to painting, wood should be scrubbed with a solution of household detergent and water with a natural bristle brush. Peeling paint should be removed with a brush or scraper, being careful not to gouge the siding. It is generally not necessary to remove all paint down to the wood, just remove damaged paint down to a sound layer. A glossy surface should be dulled by light sanding prior to painting so that the new paint will adhere.

If the wood is weathered on the surface or still intact but porous and dried out, it should be treated with a pre-prep solution. This solution can be purchased at your community paint store. One solution is to use a blend of boiled (not raw) linseed oil and turpentine, mixed roughly half and half; if the wood is "thirsty" use more linseed oil. Brush the prep on any exposed wood, reapplying multiple times anywhere the wood soaks up the solution. Allow the wood to dry for twenty-four hours before proceeding with an oil-based primer. This procedure will put integrity back into the wood, improve the adhesion of the primer, increase the coverage of the prime and topcoat, and improve the look of the finished job.

In order to clean mildew from the surface, use a solution of one-part household bleach, one-part water and a small amount of non-ammoniated detergent and scrub with a natural bristle brush. Rinse with clean water and allow to dry thoroughly. Once the wood is clean and free of damaged paint layers, caulk cracks and joints with a paintable caulking compound. Apply a coat of good primer and then paint. The primer anchors the topcoat to the wood and evens the surface. The topcoat must be applied within two weeks of the prime coat because soap-like compounds will form on the surface and may lead to inter-coat peeling. After two weeks, the prime coat should be washed with detergent to remove these compounds prior to applying the topcoat.

It is also important to remember that paint should not be applied in direct sunlight, on cold or windy days, excessively hot days, or in damp conditions.

As has been previously stated, the use of sandblasting, high velocity water blasting (greater than 100 psi), propane or butane torches, rotary sanding or other abrasive methods to remove paint are not permitted as they irrevocably damage masonry and frame buildings. Thermal devices, such as heat guns or hot plates, are not recommended as they can damage the historic siding and if used improperly can lead to flare ups hours after work has stopped.

LIGHTING

Exterior lighting generally consists of a sconce or hanging fixture on the porch, security lights, and yard lights.

PORCH LIGHTING

Light fixtures original to the building should be preserved and maintained. New light fixtures should be simple in design and be appropriate for the style of the building.

SECURITY LIGHTING

Security lights may include flood and spot lights for commercial structures. These should be mounted on the rear or sides of the building. Security lighting for commercial structures shall be full cut-off style fixtures to direct the light emitted at 45 degrees or less. For residential structures, flood lights are not allowed. Lighting options include: (1) can lighting in roof eave within 12 feet of rear wall, (2) low level pathway lighting, (3) up-lighting trees, (4) other landscape options, (5) sconce lighting over garage door, i.e. gooseneck, etc. and (6) security motion lighting on side or rear of structure.

YARD LIGHTING

Lighting for sidewalks and front yards should be small footlights rather than post-mounted fixtures.

MECHANICAL SYSTEMS

HEATING AND AIR CONDITIONING UNITS

1. Mechanical units should be located at the rear or side of a building and should be screened with shrubbery or low fencing.
2. Window air conditioners should be located in windows on the rear or side of a building and shall fit the opening of the lower sash is raised. The sash shall not be removed or replaced, and the opening cannot be made larger.

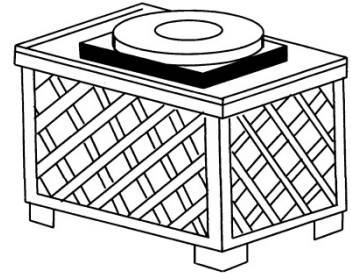

Lattice screen for compressors.

SATELLITE DISHES

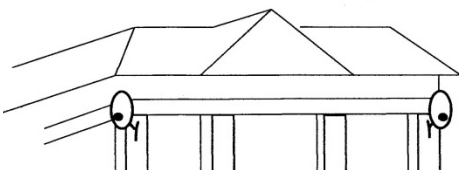

← Inappropriately installed satellite dishes on the columns.

1. Satellite dishes shall not be installed in front yards or in readily visible side yards.
2. Satellite dishes that are attached to the building shall be located on side or rear elevations, not on the front. Installation shall not require the removal of any architectural feature of the building.

GARBAGE COLLECTION

Dumpsters or garbage cans shall be placed on the rear or sides of buildings and shall be screened from the public-right-of-way by a fence and/or landscaping.

FENCES AND WALLS

Fences in the Brandon Historic District are generally constructed of wrought iron or wooden pickets. The designs vary giving a unique character to neighborhoods and streetscapes. Most of the historic walls in the Brandon Historic District are low, stuccoed brick or limestone structures that are essentially retaining walls, holding up the front yard from the sidewalk. Generally, these walls have rounded tops and are not painted. Other historic walls in the area are simple, low, unpainted brick with corbelled tops.

FENCES

REPAIR

Every effort shall be made to repair historic fences by replacing individual rotten pickets or boards or individual framing members rather than replacing an entire section of fence. When a fence component is replaced, the new component shall be of the same materials, design, size, and scale as the original.

REPLACEMENT

Replacement of an entire fence shall be approved only if the entire fence is damaged beyond repair or so severely deteriorated that it cannot be repaired. Replacement of an entire fence should not be considered only to achieve a new or uniform appearance. If total replacement is approved, the new fence shall be of the same materials, design, size, scale, height, and location as the original fence. Fences shall not be removed and not replaced.

NEW FENCES

New fences are approvable in the Brandon Historic District if they meet the following general and specific location standards:

General:

1. The style and design of a new fence shall complement the architectural style of the building and blend with the surrounding fences.
2. Structural members, such as posts and horizontal supports, must be placed on the inside of the fence, leaving the “finished” side to face other properties.
3. The following materials are inappropriate for the Brandon Historic District and are not permitted: vinyl, chain link (see exception under Specific Location below), barbed wire, plastic, metal sheets, split rails, post and rail, stockade, bamboo, and chicken wire.

Specific Location-Front Yards

1. New front yard fencing shall be no taller than three and a half feet high and have a pattern with space in between the vertical members in order to be able to see through the fence.

FENCES AND WALLS

2. Wrought iron and wood picket fences are appropriate for the Brandon Historic District.
3. Wood pickets should not be wider than four inches and be set no farther apart than three inches.

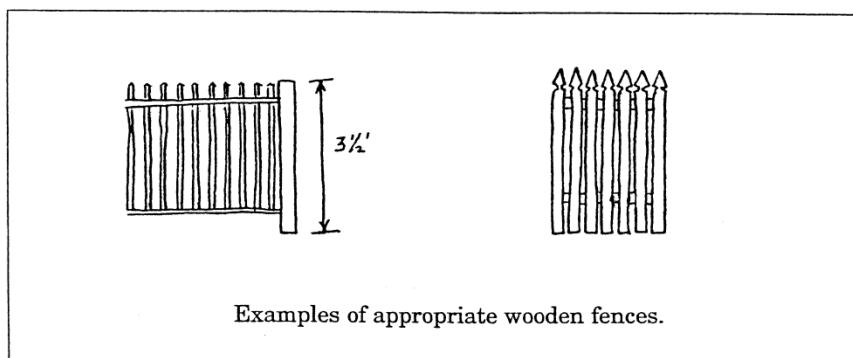

4. Front yard fences should be placed in line with other fences on the street.

Specific Location-Rear and Side Yards

1. New rear and side yard fencing shall be no taller than six feet high.
2. Chain link fences that are painted black or dark green can be used in rear yards if they are not visible from the public right-of-way. Landscaping should be used to shield the fence.
3. A backyard privacy fence should not be extended forward of the centerline of the house and is best kept in the rear of the building. On corner lots it is best to recess the fence from the property line to lessen the impact of the fence on the street and on adjoining properties.

NEW GATES

In cases where fence gates were never designed, the design of new gates shall match the design of the fence. Wrought iron fences require wrought iron gates and wood picket fences require wooden gates.

WALLS

REPAIR

Every effort shall be made to repair a wall rather than replace it. In addition, it is important to remember that historic brick must be repaired using soft mortar. See **Routine Repair and Maintenance** for masonry and **Guidelines for Rehabilitation – Bricks**.

Often if a brick wall is failing, concrete blocks can be used behind the wall for reinforcement instead of removing the historic wall and rebuilding it. The concrete blocks should be concealed, however.

FENCES AND WALLS

REPLACEMENT

Should a wall need to be replaced, the new wall shall be of the same materials, design, size, scale, and location as the original.

NEW WALLS

New walls are approvable in the Brandon Historic District if they meet the following standards:

1. Walls in the front yard shall be no higher than three and a half feet and should be compatible with neighboring walls.
2. Walls may be constructed of bricks or concrete blocks if the concrete blocks are stuccoed, not simply painted.
3. The following are inappropriate for the Brandon Historic District and are not permitted: unstuccoed concrete blocks, field stone, rubble stone, concrete balls, or other decorative features that are not historically appropriate.
4. Walls in rear yards may be no taller than six feet. Backyard walls should not extend forward of the centerline of the house and are best kept in the rear of the building. On corner lots it is best to recess the wall from the property line to lessen the impact of the wall on the street and on adjoining properties.

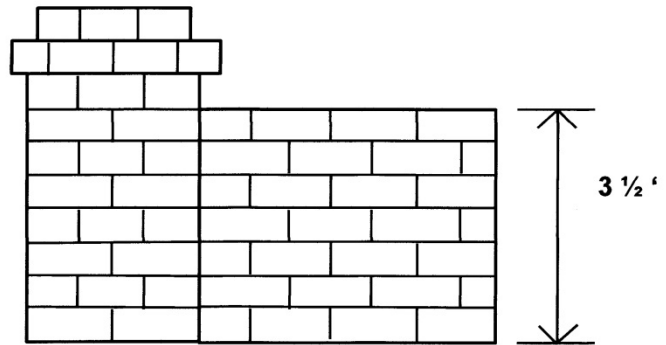

Appropriate new brick wall.

LANDSCAPING

Landscaping should not be considered the last step in a rehabilitation project. Instead, when preparing a plan for rehabilitation, one should consider existing yard area and any possible covered paths and overgrown hedges and flower beds which might give insight into the original character of the building. Care should be taken to protect the existing landscape during a rehabilitation project.

LANDSCAPING

1. Identify and protect existing landscape features, including historic plants and the configuration of beds and other plantings.
2. Do not remove any tree of six (6) inches or more in diameter. If the tree is diseased, the Commission will consider an application for a Certificate of Appropriateness to remove the tree.
3. The development and planting of flower beds does not require review.
4. Landscaping should be kept at least two (2) feet from foundation walls to reduce moisture build up.

SIDEWALKS AND WALKWAYS

1. Historic sidewalks and walkways shall be repaired and maintained. Repairs shall match the existing in material, color and texture. See **Siding – Masonry and Concrete**.
2. New sidewalks and walkways shall be constructed with brick or concrete and be no wider than five (5) feet.

FEATURES THAT ARE INAPPROPRIATE FOR FRONT YARDS

1. Features such as patios, swimming pools, gazebos, and pergolas shall be placed in the rear yard unless there is historic evidence that a feature was sited in the front yard.

BULKHEADS

Because of Brandon's terrain, there are several historic bulkheads that have been used as retaining walls for front yards. The majority of these bulkheads are walls of brick covered with stucco.

1. Historic bulkheads should be repaired and maintained. See **Routine Repair and Maintenance – Masonry**.
2. If a bulkhead is required, it can be constructed with concrete blocks that are then stuccoed to resemble the original wall. The new wall should be of the same dimensions and design as the original wall.
3. Bulkheads made of modern landscape timbers or railroad ties are not appropriate for front yards, but may be used in side yards, even with the face of the building or in rear yards. The exception for this is a corner lot, where only traditional supports should be used, not modern landscape timbers or railroad ties.

DRIVEWAYS AND PARKING

The introduction of driveways and parking lots in the Brandon Historic District can be a very difficult problem because many of the neighborhoods were developed prior to automobiles and the need for driveways and parking lots. These necessities should be designed so that they are as unobtrusive as possible, thus minimizing the effect on the historic character of the building and its neighbors. The following standards shall be considered:

EXISTING DRIVEWAYS AND PARKING LOTS

1. Existing driveways and parking lots shall be maintained and repaired with materials duplicating the existing.
2. Previously existing asphalt driveways may be replaced with bricks or concrete, however, previously existing concrete or brick drives cannot be replaced or covered over with asphalt.

MATERIALS

1. Materials shall be concrete (natural color, not tinted), exposed aggregate, gravel composed of small stones or brick (red paving brick). Concrete drives can be edged with bricks if desired. Asphalt is inappropriate for residential development and is not allowed.
2. Driveways can be built with concrete strips so that vegetation can grow in between and screen the drive. Likewise, parking areas can be built with a lattice pattern made of concrete, which allows grass to grow, softening the effect of the parking lot.

LOCATION OF DRIVEWAYS

1. Driveways shall be built on the side of the building and should allow a car to be parked beside the house or in the rear.
2. Driveways and parking lots shall not be built in front yards.
3. Circular driveways placed in front yards are inappropriate in the Brandon Historic District and are not permitted.

FENCES AND WALLS FOR PARKING LOTS

New fences and walls around parking lots are approvable in the Brandon Historic District if they meet the following standards:

1. The style and design of a new fence shall complement the architectural styles of the building along the street.
2. Structural members, such as posts and horizontal supports, must be placed on the inside of the fence, leaving the “finished” side to face other properties.
3. The following materials are inappropriate for the Brandon Historic District and are not permitted: vinyl, chain link, barbed wire, plastic, metal sheets, board and batten, split rails, post and rail, stockade, bamboo, and chicken wire.
4. Fencing shall be no taller than 3’-6” high and have a pattern with space in between the vertical members in order to be able to see through the fence.

DRIVEWAYS AND PARKING

5. Wrought iron and wood picket fences are appropriate for the Brandon Historic District.
6. Wood pickets should not be wider than four (4) inches and be set no farther apart than three (3) inches.
7. Walls shall be no higher than 3'6" and should be compatible with neighboring walls and buildings.
8. Walls may be constructed of bricks or concrete blocks if the concrete blocks are stuccoed, not simply painted.
9. The following are inappropriate for the Brandon Historic District and are not permitted: unstuccoed concrete blocks, field stone, rubble stone, or other decorative features, such as concrete balls that are not historically appropriate.

LOCATION OF PARKING LOTS

Parking areas constructed in residential areas for multi-family developments and off-site parking lots for residential uses requiring additional parking such as a bed and breakfast or tour home, shall meet the following standards. A landscape plan incorporating these standards shall be submitted showing proposed exterior and interior landscaping.

1. The lot shall be set back six (6) feet from any property line. These buffer areas shall be landscaped to provide a screen for the parking lot.
2. The design of such parking areas must incorporate existing trees and provide for their maintenance (i.e. do not pave up to the edge of the tree, provide an areas of green space around the tree so that it can survive the impact of the parking lot).
3. Lighting for parking areas should be as unobtrusive as possible, should focus down and not spill over on adjacent buildings.

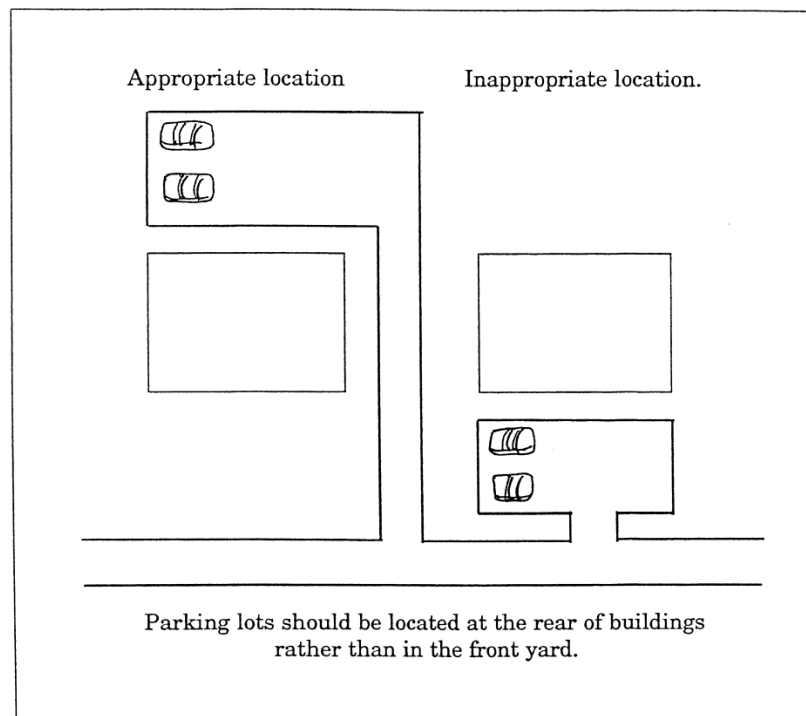

ADDITIONS AND DECKS

Often it is necessary to make additions to buildings, either to accommodate a new use or to provide additional space for a building's inhabitants. Additions can be designed for historic buildings so that there is the least possible loss of historic materials and so that character-defining features are not obscured, damaged, or destroyed. Designs for additions and decks should take into consideration the following standards:

ADDITIONS

1. Additions shall be located at the rear of the building, unless it is located on the side toward the rear, not on the front or readily visible area of a side.

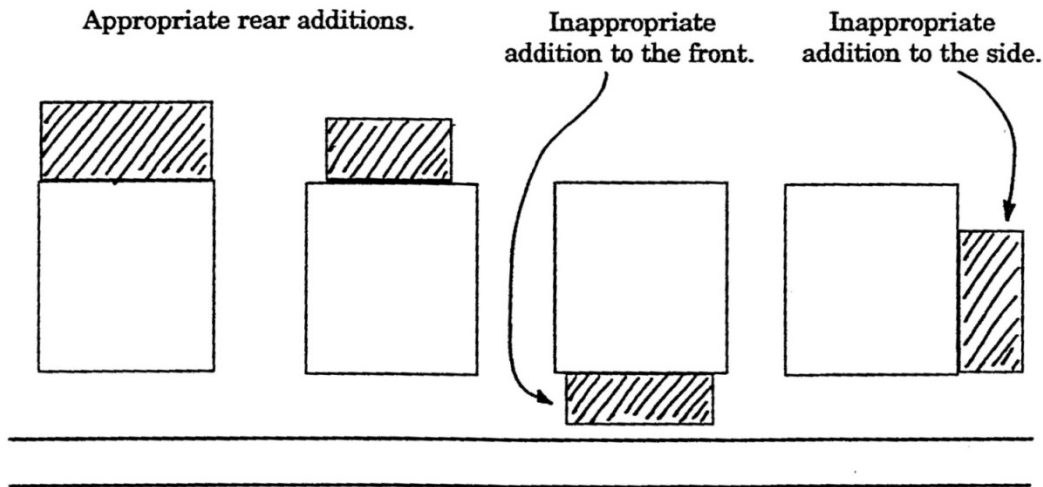

Additions should be located at the rear of the building, not at the front or readily visible side.

2. Additions shall not be taller than the existing building and shorter if possible.
3. The shape of the addition shall be compatible with the existing building (i.e. tall and narrow or short and wide). In addition, the roof form should be compatible with the historic building and consistent with contributing roof forms along the street.
4. Foundation height, floors, and eave lines in the addition shall line up with those in the existing building.
5. Windows shall be similar in proportion and size, but need not necessarily duplicate the existing windows exactly. However, the windows on such additions shall follow the pattern established on the side of the existing building.

ADDITIONS AND DECKS

6. Doors shall be similar in proportion and size, but again need not necessarily duplicate the existing doors exactly. If the addition is located on the side elevation, the doors shall be located on the side or rear of the addition.
7. Materials used in the addition shall be the same as are found on the existing building (i.e. clapboard-sided buildings should have clapboard-sided additions.) However, additions to brick or stone buildings can be wood frame. Roof materials should be the same on both the existing building and the addition.
8. Ornamentation on the addition shall not be more elaborate than the existing building.
9. Additions should be designed in such a way as to be reversible if the addition is removed. For example, it is best to use existing door and window openings to connect the existing building with the addition. It is also best to retain the siding that is covered by the addition, either by covering it with a new siding or using the original siding as a design feature of the new room, instead of removing the original siding.
10. Additions should be designed so that the addition does not appear to be a part of the existing building. This is a difficult concept because the addition must blend in with the rest of the building, but at the same time be clearly viewed as a new addition.
11. Adding a second story addition to a one-story building is not permitted.

DECKS

1. Decks shall be built at the rear of buildings, with the sides set in from the edge of the existing building.
2. Decks and their railings shall be compatible in material, color, and detail with the existing building, but shall be simple in design as not to draw attention from the character of the existing building.
3. Decks should be designed in such a way as to be reversible if the deck is removed.
4. Significant features of the existing building shall not be removed in order to construct a deck.
5. The deck should be painted or stained in colors compatible with the color of the existing building.
6. The deck shall line up with the floor level of the existing building. The deck framing shall be screened with lattice panels or landscaping.

**COMMERCIAL BUILDINGS:
*STANDARDS AND GUIDELINES
FOR REHABILITATION AND
RESTORATION***



ROOFS

The roof shape of commercial buildings is important in defining the building's overall architectural character. Roofs on Brandon's early commercial buildings were gables and were covered with wood shakes, slate and metal. Most of these buildings were lost in fires in the downtown area. In the later part of the 19th century, they became flatter with a slight slope to shed water. Flat roofs were eventually built-up roofs covered with gravel and tar. Any changes to commercial building roofs should take into consideration the following guidelines.

REPAIR

Roofing material shall be retained unless deteriorated. Every effort should be made to retain metal, slate or tile roofs. When partially reroofing a deteriorated roof, coverings shall be replaced with new materials that match the old in composition, size, shape, and texture.

Repair of metal roofs requires knowledge about the interactions between metals, see **Siding-architectural metal**. For example, metals such as tin and copper will react chemically with one another, resulting in galvanic corrosion. In addition, coating a metal or tin roof with hot tar to stop a leak will hasten the deterioration of the metal.

Repair of slate roofs should be accomplished with copper nails to secure the slate, not iron nails which will rust and allow the slate to become dislodged.

REPLACEMENT

1. The original roof shape or pitch shall not be changed, with one exception. If a flat roof is hidden behind a parapet, it can be changed to give it a slope as needed to drain water. However, the new pitch must still be hidden behind the parapet and not visible from the street.
2. The configuration of the roof shall not be changed by adding features that were not original to the building such as dormer windows, vents or chimneys.
3. Applications for the removal of a metal, slate or tile roof are carefully weighed by the Commission. These roofing materials will last for well over 100 years and may only need limited replacement and repair as opposed to complete replacement.
4. If the roof is visible from the street, new roofing materials shall not be used which differ to such an extent from the old in composition, size, shape, color or texture that the appearance is altered. If a new roof color is planned it should be appropriate to the building and blend in with other buildings on the street.
5. If the roof is flat or completely hidden behind a parapet, new rubber-based roofing material can be used.
6. Roll roofing and corrugated metal are not acceptable as replacement roofing materials for visible roofs.

DORMERS AND OTHER DESIGN ELEMENTS

Every effort shall be made to repair and restore character-defining elements such as dormers, vents, towers and eave treatments by patching and splicing or by limited replacement with materials matching the original in size, shape, and composition. See **Routine Repair and Maintenance** for wood and windows. These elements shall not be visually altered, covered over, or removed from the building.

If an element is damaged or deteriorated to a point where it cannot be repaired, the replacement shall match the original in design, material and color. Likewise, if there is evidence that a feature is missing, the feature should be replicated using an existing prototype or using historical, physical or pictorial evidence.

CORNICES

The cornice is important in defining the style and character of a commercial building. Often the majority of the architectural ornamentation can be found on the cornices at the roof line of the building or on a cornice placed over the storefront area. Each commercial building in Brandon offers a different variety ranging from a simple corbelled brick to elaborate bracketed cornices crafted from sheet metal, wood or terra cotta. It is important to preserve, maintain, and replicate where missing, these significant elements of the commercial façade. The following standards shall be met when dealing with cornices.

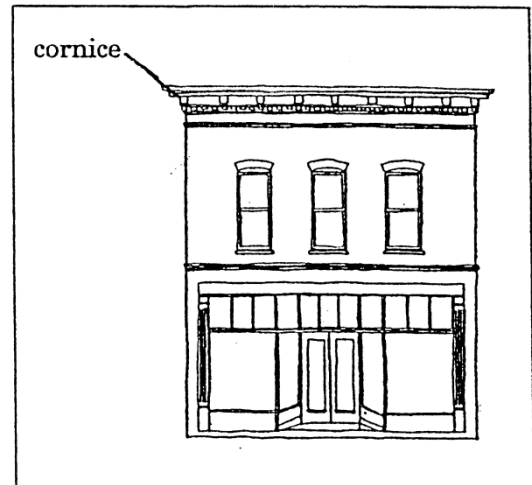

1. Every effort shall be made to repair cornices by patching and splicing or by limited replacement with materials matching the original in size, shape, and composition. For brick or terra cotta cornice repair see **Routine Repair and Maintenance** and **Siding-brick**, for metal cornice repair see **Routine Repair and Maintenance- architectural metal** and **Siding-architectural metal**.

2. If replacement of a sheet metal cornice is necessary because of advanced deterioration, the replacement shall match the original in design, material, and color. Fiberglass can also be used to replicate a deteriorated sheet metal cornice as long as the new one matches the original in profile, dimensions, and texture.

3. If the cornice is missing, it may be replaced using photographic or physical documentation to design a new one. If there is no documentation the new cornice should be designed in wood or metal similar in appearance to other historic cornices of the same style in downtown Brandon.

4. A new cornice shall not be added to buildings where there is no evidence that one existed.

CHIMNEYS

Chimneys are important elements of a building's character and shall be repaired and maintained even if they are not in use. For repair of chimneys see **Siding-masonry**. It is inappropriate to repair a chimney by simply applying a coat of stucco to stabilize the masonry. Stucco should be added only in cases where the existing chimney is stuccoed and needs repair.

ROOFS

If a historic chimney is deteriorated to such an extent that it must be rebuilt, replacement materials shall be the same in style, composition, color, texture and strength as the damaged materials. The appropriate mortar composition, color, texture, and application must also be used when rebuilding. The same bonding pattern and joint width and profile shall be maintained.

A historic chimney shall not be removed. Likewise, a chimney shall not be added when there is no evidence that a chimney existed.

GUTTERS

Historic gutters shall be repaired and maintained where possible. If new gutters must be installed, the half-round type is preferred, but molded gutters are also acceptable. Gutters and downspouts should not be installed in such a way as to remove or conceal significant architectural details. Splash blocks or concealed piping should be installed to provide proper drainage away from the building, so as to avoid water damage to the building.

SKYLIGHTS, SOLAR COLLECTORS, AND MECHANICAL EQUIPMENT

Air conditioning, transformers, solar collectors, and skylights shall be installed so that they are inconspicuous from the public right-of-way, such as on the rear of the building or flat roofs behind the parapet. The installation shall not damage or obscure character-defining features.

Skylights should be flat or flush with the roofline, not convex.

The majority of commercial buildings in Brandon are sided with brick. Other materials are stone, concrete, stucco, metal and wood. As with residential buildings, the type of siding is important in defining the historic character of the building and its architectural style.

MASONRY

Brick, Stone, Terra Cotta, and Concrete

Brick, stone, terra cotta, and concrete are siding materials that are also found in the Brandon Historic District. Early **bricks** were generally composed of clay mixed with silt or sand, which was then pressed into molds and then fired in a kiln. In the 1870s the method of producing the brick through an extrusion process made the bricks more uniform and durable. Historic mortars, consisting mainly of lime and sand, were designed to provide flexibility, not rigidity, to a building. The softer historic bricks expand and contract with the weather and the soft mortar allowed this movement. When soft bricks expand and hit hard mortar, the faces of the bricks spall off. Historic mortar has a high lime content which is also slightly soluble in water and is able to self-seal small cracks that may occur. **Stone** is one of the more lasting of masonry building materials. **Terra cotta**, which came into popularity in the late 19th century, is a kiln dried clay product which is generally highly decorative. Early **concrete** was made of tabby, volcanic-ash and later naturally occurring hydraulic cements. By the turn-of-the-century, Portland cement was used to make precast concrete blocks. Many of these blocks were made to resemble stone blocks and concrete trim was also substituted for sandstone trim.

REPAIR

While masonry is among the most durable of historic building materials, it is also very susceptible to damage by improper maintenance or repair techniques and harsh or abrasive cleaning methods. Every effort shall be made to repair masonry siding by patching or splicing. See **Routine Repair and Maintenance**.

REPLACEMENT

Damaged areas of masonry walls shall be repaired using as much of the original brick or stone as possible. Replacement materials shall be the same in style, composition, color, texture, and strength as the damaged materials. The appropriate mortar composition, color, texture and application must also be used when rebuilding a masonry wall. The same bonding pattern and joint width and profile shall be maintained.

REPOINTING MASONRY

Repointing of the mortar joints may be necessary where there is evidence of deterioration such as disintegrating mortar, cracks in mortar joints, loose bricks, or damaged plasterwork. Repointing of masonry should only be attempted by professionals who have experience with historic masonry and only after a test panel is completed in an inconspicuous location. (See **Repointing Masonry- Residential Buildings for a diagram.**) The deteriorated mortar should be removed by carefully hand-raking the joints back to about $\frac{3}{4}$ ". Mechanical tools are not approved for cleaning the joints as they often damage the edges of the brick. The joints are then filled with new

SIDING

mortar that duplicates the historic mortar in strength, composition, color and texture. As mentioned above, historic mortar is soft in strength because it is high in lime content. The new mortar should have the same composition which can generally be achieved by mixing one part lime by volume to two parts sand. In order to match the color of the historic mortar, colored sands or mineral pigmented mortar mixtures can be used. Organic and chemical colorants tend to fade and are not recommended. Finally, the historic mortar joint is duplicated in width and joint profile. Too wide of a profile will create a building where you seem to see only the mortar, not the bricks. Excess mortar should be cleaned off of the brick. Only the deteriorated mortar should be removed and repointed. Removing non-deteriorated mortar from sound joints, then repointing the entire building to achieve a uniform appearance is not allowed.

CLEANING MASONRY

Masonry acquires a patina over time due to weathering and other conditions. This patina is a part of the historic character of the building and should be taken into consideration. Cleaning of masonry should not be considered if the purpose is to give the building a new and uniform look. Masonry shall be cleaned only when necessary to halt deterioration or remove heavy soiling. Further, cleaning shall take place only after masonry surface cleaning tests. Tests should be observed over a sufficient period of time so that both the immediate effects and the long-term effects are known to enable selection of the gentlest method possible, such as low-pressure water (not to exceed 600 PSI) and detergents using natural bristle brushes. The use of high-pressure water to clean masonry will damage original masonry and mortar joints and shall not be used. Cleaning with chemical products generally damages masonry or leaves a residue on the masonry and is not permitted unless the product is approved by MDAH, Historic Preservation Division.

WATERPROOF COATINGS

Waterproof coatings are not recommended for historic brick surfaces because they trap moisture which causes spalling of the surface. Bricks are designed to pass moisture from the inside surface to the exterior, therefore using a waterproof sealer will cause moisture problems on the interior surfaces as well. If it is believed that a coating is necessary, a breathable product may be approved by the Commission upon review by MDAH, Historic Preservation Division.

PAINTING

Masonry which has never been painted shall not be painted. On a case by case basis, the Commission may approve a historically unpainted brick building to be painted if the brick and mortar are extremely mismatched from earlier repairs or repointing. However, if the earlier mortar repairs are the wrong color, but the bricks are correct, the Commission may approve the painting only of the mortar joints to match the historic mortar color of the rest of the building.

STUCCO

Stucco was historically added to a building as a part of the architectural style or as protection against moisture. Therefore stucco shall not be removed from a building unless to repair deteriorated areas.

REPAIR AND REPLACEMENT

Early stucco coatings were lime-based and were soft enough for the brick that they covered to expand and contract. Hard stucco placed over soft bricks will cause the brick to spall taking the stucco with it. Stucco repair must match the original in strength, composition, color and texture. A test panel should be completed before patching stuccoed walls.

CLEANING

Stucco acquires a patina over time due to weathering and other conditions. This patina is a part of the historic character of the building and should be taken into consideration. Cleaning of stucco should not be considered if the purpose is to give the building a new and uniform look. Stucco shall be cleaned only when necessary to halt deterioration or remove heavy soiling. Further, cleaning shall take place only after surface cleaning tests. Tests should be observed over a sufficient period of time so that both the immediate effects and the long-term effects are known. Tests enable selection of the gentlest method possible, such as low-pressure water (not to exceed 600 psi) and detergents using natural bristle brushes. The use of high-pressure water to clean stucco will damage original material and shall not be used. Cleaning with chemical products generally damages stucco or leaves a residue and is not permitted unless the product is approved by MDAH, Historic Preservation Division.

WATERPROOF COATINGS

Waterproof coatings are not recommended for historic stucco surfaces because they trap moisture which causes spalling of the surface. Using a waterproof sealer will cause moisture problems on the interior surfaces as well. If it is believed that a coating is necessary, a breathable product may be approved by the Commission upon review by MDAH, Historic Preservation Division.

PAINTING

Stucco which has never been painted shall not be painted. On a case by case basis, the Commission may approve a historically unpainted stuccoed building to be painted if the surface is defaced from earlier repairs.

ARCHITECTURAL METALS

Architectural metal features and siding are important in defining the overall character of a building. Metals commonly used in historic buildings include lead, tin, zinc, copper, bronze, brass, iron, steel, and to a lesser extent, nickel alloys, stainless steel and aluminum. Historic metal building components were often created by highly skilled, local artisans, and by the late 19th century, many of these components were prefabricated and readily available from catalogs in standardized sizes and designs.

REPAIRS

Every effort shall be made to repair historic metal siding by patching or splicing. See **Routine Repair and Maintenance**.

REPLACEMENT

If metal siding must be replaced, the replacement materials shall be the same in style, composition, color, and texture as the damaged materials. Care should be taken to assure that the replacement pieces are attached to the building by the correct means. Removing a major portion of the historic architectural metal instead of repairing and replacing only the deteriorated metal in order to create a uniform or improved appearance is not allowed.

If metal siding is missing, the replacement siding shall be based on historical, pictorial, and physical documentation.

Metals shall be cleaned only to remove corrosion prior to repainting or applying other appropriate protective coatings, not to create a “new” look. Often the metal has acquired a patina which may be a protective coating on some metals, such as bronze or copper, as well as a significant historic finish.

The following issues shall be addressed prior to cleaning of historic metals:

1. Identify the particular type of metal prior to any cleaning procedure.
2. Test to assure that the gentlest cleaning method possible is selected.

Cleaning soft metals such as lead, tin, copper, ternplate, and zinc should be with appropriate chemical methods because their finishes can be abraded by blasting or other abrasive means.

PAINTING

Some metals such as copper, bronze, or stainless steel were often meant to be exposed (unpainted) and shall not be painted if historically not covered. Likewise, those metals that were historically painted are to remain painted.

OTHER CONSIDERATIONS

Incompatible metals shall not be placed together without providing a reliable separation material. Such incompatibility can result in galvanic corrosion of the less noble metal. For example, copper will corrode cast iron, steel, tin and aluminum.

REMOVAL OF FALSE FRONTS

In the 1960s and 70s an effort to “update” downtown to attract more customers resulted in the addition of aluminum, wood, stucco or other panels covering entire second and upper floor facades. The removal of the false fronts is encouraged and often once removed, the original windows and ornamentation are revealed. The rehabilitation of materials recovered from under the siding should follow the guidelines for the particular element.

SYNTHETIC SIDING

Property owners are often attracted to synthetic sidings such as vinyl, aluminum, EIFS (synthetic stucco), Masonite, and imitation brick siding because of manufacturer's claims that the material will keep exterior moisture from entering the building and that the siding will not have to be repainted every 5-10 years. While there might be some perceived advantages to synthetic sidings, there are some major disadvantages. The application of synthetic siding to historic buildings in the Brandon Historic District is not approved for the following reasons.

1. The synthetic siding conceals the historic siding and character, reducing the integrity of the historic building itself and the historic district as a whole. Synthetic siding creates a different profile, surface level and appearance than the existing siding. Placing new siding over existing siding causes recessed areas to appear deeper and project in surfaces to appear shallower, thus dramatically altering the building's appearance. In addition, during installation historic elements are often removed to make it easier to apply the siding. The removal of any ornamental details diminishes the character of the building.
2. Synthetic siding does not allow moisture to pass through it and therefore, moisture can get trapped behind the siding, accelerating the deterioration of the wood siding. Historic wood siding was intended to breathe and pass moisture from the interior of the structure to the exterior. Synthetic sidings do not allow this moisture to exit to the outside. Consequently, the moisture is trapped and the wood deteriorates.
3. In addition, the lifetime of synthetic sidings is unknown. Manufacturers claim some of the sidings will last to 30 years. During this time, because the wood siding is unmonitored and inaccessible, it is very likely that it will deteriorate, possibly to the point that structural problems may threaten the integrity of the building.

OTHER CONSIDERATIONS

The factory applied finish of the vinyl and most other synthetic sidings will deteriorate over time, due to exposure to the environment and to ultra violet light. When these finishes have deteriorated significantly, they will have to be painted, just as the wood siding that it covered would have had to be. In addition, synthetic siding materials typically cannot withstand impact damage as well as wood; a damaging hailstorm has been known to leave a synthetic-sided building heavily dimpled. With constantly changing technologies, synthetic materials often go out of fashion or the technology is replaced by other technologies. Finding replacement parts of cladding systems as they get older can be time consuming and costly and may not match the color of the rest of the building, making it necessary to paint the entire building. It is difficult to find a paint that will adhere to synthetic siding for any length of time.

The addition of synthetic siding can detract from a building's resale value because it may be believed that siding was installed to hide structural problems, which happens often. Potential purchasers may find it difficult to fully inspect the building for problems because the siding cannot be easily removed.

The use of composite concrete board (also called Hardi-plank) is an acceptable alternative in the Historic District.

ARCHITECTURAL ORNAMENTATION

Architectural ornamentation on commercial buildings includes a wide range of features such as brackets, window and door hoods, dentils, cornices, molding, shingles, pilasters, finials, cresting, and corbelling. These details are most often made of wood, cast iron, sheet metal, terra cotta, or stucco. Ornamentation adds to the character of a building and enhances its value.

REPAIR

Original detailing shall be retained and repaired. Every effort shall be made to repair features by patching or piecing in using recognized preservation methods. See **Routine Repair and Maintenance** and the **rehabilitation sections on wood siding** for wood ornamentation; **masonry** for corbelling or terra cotta; and **architectural metals** for metal cresting, finials, cast iron columns, pilasters, and window hoods.

REPLACEMENT

If an element is damaged or deteriorated to a point where it cannot be repaired, the replacement shall match the original in design, material and color. Likewise, if there is evidence that a feature is missing, the feature should be replicated using an existing prototype or using historical, physical or pictorial evidence.

REMOVAL OF DETAILS

No architectural features that are original to the building should be removed. Damaged details must be repaired or replaced.

NEW DETAILS

Architectural features shall not be added to an existing building unless there is photographic evidence that the features originally existed.

BALCONIES

A number of commercial buildings retain their balconies. Existing balconies add to the character of the streetscape and help to define downtown Brandon. **(For wood or metal canopies see that section).**

REPAIR

Every effort shall be made to repair balconies and their details by patching, splicing, consolidating or otherwise reinforcing deteriorated sections. See **Routine Repair and Maintenance**.

REPLACEMENT

Where replacement of a balcony or its details is necessary, it shall be replaced with the same materials used in original construction to match the original in design, scale, and placement. See **Architectural Ornamentation**. If a detail that is to be replaced is found to be non-historic, the replacement detail shall be designed to match the original feature of the balcony.

REPLACING MISSING OR MODERNIZED FEATURES

If the original balcony is missing or has been modernized to a point where it is difficult to distinguish the historic appearance, the balcony may be replaced using photographic documentation to design the new one. If there is no documentation, the new balcony should be designed in wood and in keeping with the architectural style of the building. The new design should take into consideration balconies of other buildings of the same age and style in the downtown. Ornamentation that is incompatible with the style of the building shall not be included in the new design.

REMOVING A BALCONY OR BALCONY FEATURES

A balcony that is historically a part of a building shall not be removed for any reason and not be replaced. The replaced balcony shall convey the same visual appearance as the removed balcony. In addition, balcony components that are removed for any reason, must be replaced and must match the original in design, material, size and style. Components that are removed must be replaced.

ADDING DETAILS

Undocumented historic details shall not be added to a balcony as they convey a false sense of history.

ADDING OR EXTENDING A ROOF OVER A BALCONY

Roofs shall not be added or extended over a balcony unless there is historic evidence of the roof. If there is pictorial or other evidence, the new roof shall duplicate the original in materials, size, shape, design, and location.

SCREENING

Front balconies shall not be screened. Rear balconies that are covered by a roof and that are not on corner lots can be screened using the following standards:

1. the screen is placed behind the columns and balustrade or roof supports.
2. the framing system is a simple design which is painted to match the color of the columns or trim, with as few vertical and horizontal divisions as possible.

BALCONIES

3. the screen should fit from framing member to framing member without any infill material between the screen and the member.

BALCONY ROOFS

See **Roofs**.

ENCLOSING A FRONT, SIDE, OR REAR BALCONY FACING A STREET

Front, side, and rear balconies facing a street shall not be enclosed.

ENCLOSING A REAR BALCONY

Rear balconies that are covered with a roof can be enclosed using the following standards:

1. balconies can be enclosed with the use of large sheets of glass that are recessed behind the existing posts, columns, and balustrade.
2. the framing system to support the glass must be simple and unobtrusive and designed with as few vertical and horizontal divisions as is possible.
3. the glass panels should fit from framing member to framing member without any infill material between the glass.
4. the glass shall be clear, not tinted or etched.
5. the original windows and door of the building should still be visible to the outside, thereby maintaining the character-defining elements of the building.
6. the framing system should be painted the trim color.

NEW BALCONIES

1. if there is no evidence that a front balcony existed, a new front balcony shall not be approved.
2. if there is no evidence that a rear balcony existed, one can be added if the design is compatible in scale, size, and materials with the building to which it is attached. The design should draw on other balconies in the downtown area and should meet the following standards:
 - a. new rear balconies should not be any wider than the width of the building to which it is attached.
 - b. the roof shall be no higher than that of the building to which it is attached, and the roof form should be compatible with that of the existing building.
 - c. the floor and eave lines should line up with those in the existing building.
 - d. ornamentation shall not be more elaborate than the existing building.

WINDOWS

Windows on upper floors and display windows on the ground floor are important in defining the historic character of a commercial building. Therefore, the integrity of both types of windows and their surrounds should be preserved through the use of the following guidelines:

REPAIR

Every effort shall be made to repair and restore windows and their decorative features (frames, sills, heads, hoodmolds, jambs and molding) by patching and splicing or by limited replacement with materials matching the original in size, shape, and composition. See **Routine Repair and Maintenance**.

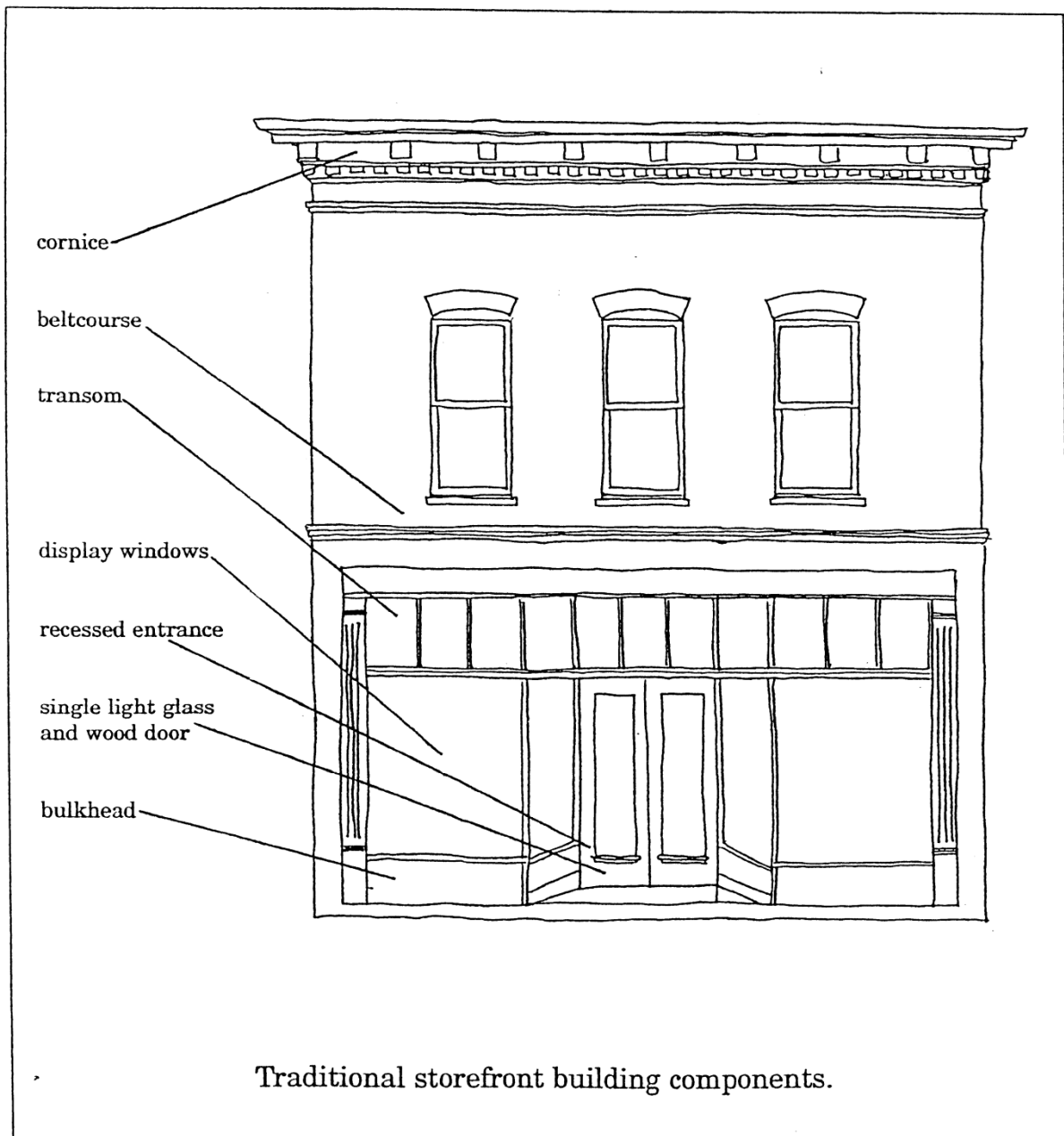

WINDOWS

REPLACEMENT

1. Repair of upper floor and display windows should always be considered before replacement; then selective window replacement is recommended over complete replacement of all windows.
2. If replacement is necessary because of advanced deterioration, the replacement window shall match the original window with regard to the following standards:
 - A. Design – for example, double-hung windows should be replaced with double-hung windows.
 - B. Materials – constructed from the same materials (i.e. wood windows should be replaced with wood windows).
 - C. Size – the window opening shall not be blocked-down or made larger.

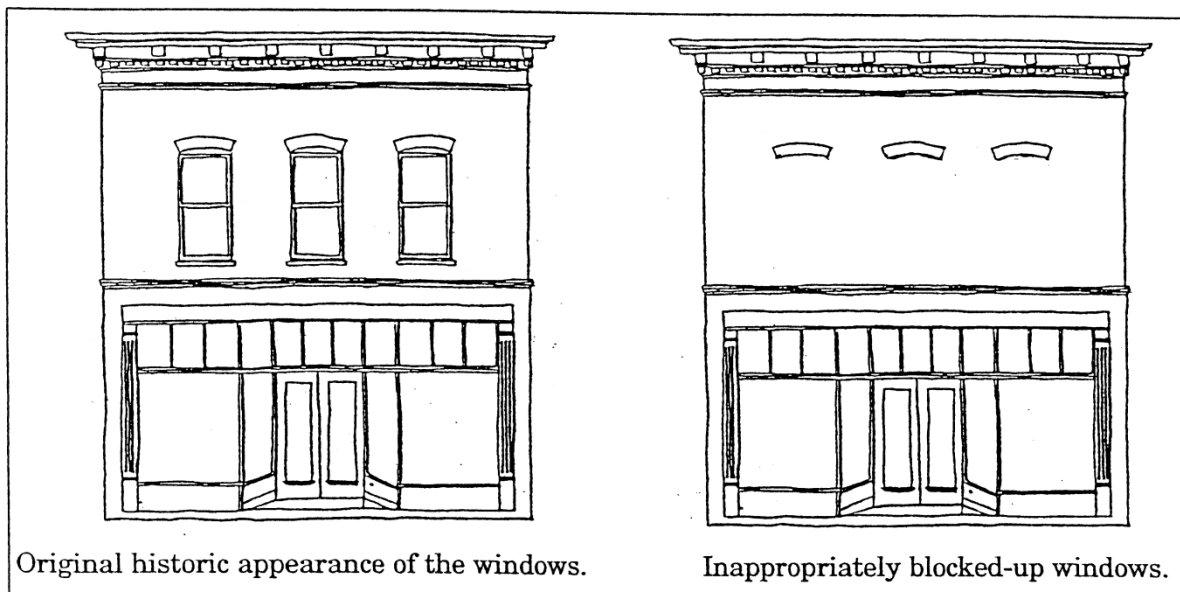

- D. Placement – replacement windows shall be placed in the original location.
- E. Configuration of window panes – the replacement shall have the same size, number and placement of window panes.
- F. Characteristics of the glass – clear glass shall be replaced with clear glass.
- G. Snap in muntins, which simulate the subdivision between the lights, shall not be used. Only true divided light sash shall be used because snap-ins alter the historic appearance of the building because they lack the depth and profile of historic windows.
- H. Depth of reveal (the distance between the front of the wall and the window) of the replacement window shall be the same as the original window.

WINDOWS

3. If a non-historic upper floor window or display is to be replaced with one that is more in keeping with the original window, the replacement window shall be an accurate restoration using the historic, pictorial, and physical documentation. Where this information is not available, a new design shall be used that is compatible with the window openings and the historic character of the building. Missing upper floor windows where there is no evidence of their configuration can be replaced with one-over-one, double-hung, wooden windows that fit the opening. Design for the replacement of a display window should follow the character of commercial buildings of the same style if historic documentation is not available.

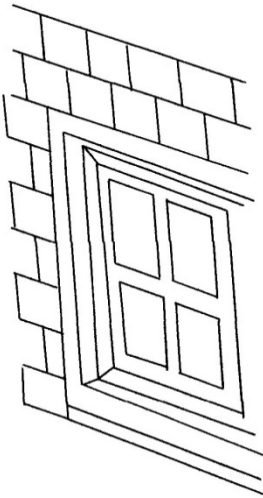

Window reveal- the setback of the window from the face of the wall.

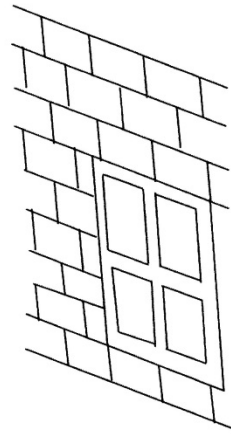

A window that is flush with the wall. There is no reveal.

4. Vinyl-clad wood windows, single or double-glazed, with true divided lights may be acceptable replacement windows for those that are not in the public view, such as on the back of a building, if the window matches the original configuration and profiles. The depth of reveal must be maintained. Raw aluminum, bronze-colored aluminum, and painted aluminum or vinyl-clad windows that do not have true divided lights are not acceptable replacement windows.

NEW WINDOW OPENINGS

New window openings shall not be created on the fronts or sides of buildings. On a case-by-case basis, the Commission may consider new windows on the rear of a building or into an exposed party wall. Such design should be compatible with the overall design of the building, but not necessarily duplicate the fenestration pattern and detailing of a character-defining elevation.

REMOVAL OF WINDOWS

Historic window openings and their sashes shall not be removed, and the opening covered over because this significantly changes the character of the building.

COVERING WINDOWS

Windows shall not be covered with plywood or any other materials.

WINDOWS

WHEN INTERIOR CHANGES AFFECT THE EXTERIOR

If it is necessary to drop a ceiling for a new interior use, there shall be a set-back in the design to allow for the full height of the window opening so that the ceiling does not cut across the window.

WINDOW SURROUNDS AND BULKHEADS

Original decorative features, such as crown moldings, entablatures, bulkheads and pilasters, shall be preserved and maintained. These features shall be repaired by patching and splicing or by limited replacement with materials matching the original in size, shape, and composition. If replacement of a feature is required because of its advanced deterioration, the replacement feature shall match the original feature with regard to design, materials, size, placement and color.

Window surrounds that are original to the building shall not be removed.

Window surrounds shall not be added to historic buildings unless based upon documentation and then shall conform to historic appearance and materials.

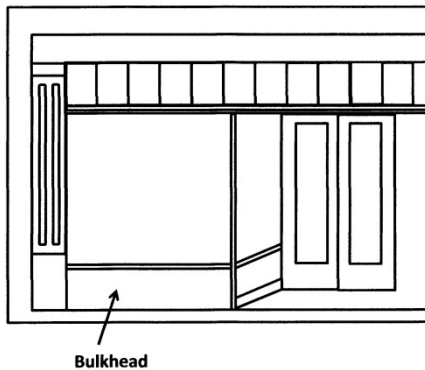

Bulkheads (the area under the display windows) in Brandon are generally wood panels or brick. These bulkheads are important in defining the storefront and careful attention should be taken to repair and preserve this part of the window area. For repair and rehabilitation of wood bulkheads see **Siding-wood**, for brick see **Siding-Masonry**. If the original bulkhead has been lost through previous renovations and if photographic or other historical evidence is not available, the bulkhead should be replaced with one of wood or brick that matches other original bulkheads on the street.

WINDOW COATINGS

Tinting, reflective coatings, and opaque window coverings on upper floor windows, display windows, and transom panels are not allowed as they change the look of the historic glass. However, to protect interior fabrics from ultraviolet rays, clear adhesive filtering film designed to reduce the destructive efforts of ultraviolet light can be applied to the interior surface of the windows.

STORM WINDOWS

Storm windows should be installed on the interior of the window so that the appearance of the historic window is not changed. There are several kinds of interior storm windows including those that attach to interior frames with magnets, Velcro, screws or clips. While interior storm windows are preferable, exterior storm windows are allowed in the Brandon Historic District if they blend in with the building and take into consideration the following standards:

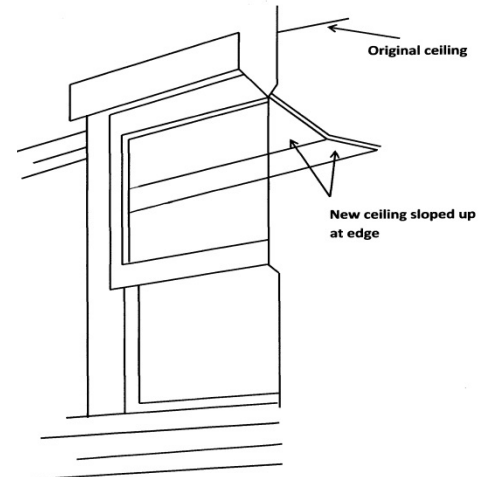

Correct method of lowering interior ceiling without affecting the exterior.

WINDOWS

1. Care should be taken when installing storm windows to ensure that original windows and window features are not destroyed or obscured.
2. The shape and general appearance shall match the existing window as closely as possible by being full view (single sheet of glass) or sectioned in an unobtrusive manner so as not to obscure or distort the existing window. The meeting rail of the storm window shall align with the meeting rail of the window to which it is applied.
3. Storm windows shall be made of wood, baked enamel, or metal painted to match the window trim. Raw metal or bronze-colored storm windows are not acceptable.
4. The glass shall be clear, not tinted.
5. Storm windows should have adequate ventilation so that moisture is allowed to escape and does not build up and cause deterioration of the sash.
6. Exterior track storm windows are not acceptable because they obscure historic detailing of the window and generally jut out beyond the wall surface.

SHUTTERS

Shutters that are original to a building should be preserved and maintained. If repairs are necessary they shall be repaired by patching and splicing or by limited replacement with materials matching the original in size, shape, composition. If replacement of a shutter is required because of its advanced deterioration, the replacement shutter shall match the original feature with regard to design, materials, size, placement, and color. Other standards for shutters are as follows:

1. Shutters shall not be added to buildings unless there is evidence that shutters were original to the building.
2. Replicated shutters shall be of wood or appropriate material (vinyl, aluminum or other materials are not appropriate because they do not reflect the character of wood and are incompatible with the materials of historic building).
3. Shutters must fit the window opening so that when closed they cover the window opening.
4. Shutters should be affixed to the inside of the window frame using hinged hardware and shutter dogs so that they close.
5. Shutters shall not be removed and not placed back on the building after repair.
6. Shutters can be used to conceal missing windows – openings that have been blocked-in. It is hoped that eventually these windows will be restored.

SECURITY BARS

Exterior security bars are inappropriate in the Brandon Historic District because they change the historic appearance of the window. In addition, bars tend to give a negative impression of the neighborhood. If bars are necessary, they should be of a simple, not decorative design and should be placed on the interior and preferably only on the side and rear elevations.

DOORS

Storefront doors and doors to upper stories are important in defining the historic character of a commercial building. Generally storefront doors are largely glass coinciding with the placement of the bulkhead. Entrances to upper floors are generally single, wood, paneled doors. Changing the historic appearance of doors through the use of inappropriate design, materials, finishes, or colors diminishes the character of the building and therefore is not permitted.

REPAIR

Every effort shall be made to repair and restore doors and their decorative features by patching and splicing or by limited replacement with materials matching the original in size, shape and composition. Deteriorated doors can be refinished, cracks and holes can be filled, hinges can be repaired, and rotten frames can be repaired or replaced. In addition, original hardware shall be repaired and retained. See **Routine Repair and Maintenance**.

REPLACEMENT

1. Repair of historic doors should always be considered before replacement, but if replacement is necessary because of advanced deterioration, the replacement door shall match the original with regard to the following standards:

- A. Design – for example, a six-panel door shall not be replaced with a four panel door.
- B. Materials – constructed of the same materials (i.e. a wood door should be replaced with a wood door).
- C. Size – the door opening shall not be blocked-down or made larger.
- D. Placement – the replacement door shall be placed in the same opening as the original door.
- E. If the storefront doors are glazed (have glass panels), then the following standards shall be met.
 - 1. Configuration of the window panes – shall have the same size and number.
 - 2. Characteristics of the glass – clear shall be replaced only with clear glass.
 - 3. Snap-in muntins, which simulate the subdivisions between the lights, shall not be used. Only true divided light sash shall be used. Snap-ins alter the historic appearance of the building because they lack the depth and profile of historic windows.
- F. Depth of reveal (the distance between the front of the wall and the door) – of the replacement door shall be the same as the original door reveal.
- G. Hardware from the original door should be used on the replacement.

2. If a non-historic door is to be replaced with one more in keeping with the original door, the replacement shall be an accurate restoration using historical, pictorial, and physical documentation. Or where this information is not available, be a design that is compatible with the door opening, the historic character of the building and the design of doors of the same period in downtown Brandon. These are generally single light wood doors with a panel at the bottom.

DOORS

NEW DOOR OPENINGS

New door openings shall not be created on the fronts or sides of buildings. On a case by case basis the Commission may consider new doors on the rear of a building or into an exposed party wall. Such new door design shall be compatible with the overall design of the building, but not necessarily duplicate the detailing of a door on a character-defining elevation.

REMOVAL OF DOORS

Historic doors shall not be removed, and the opening covered over.

DOOR SURROUNDS

Original decorative features, such as fanlights, sidelights, transoms, crown molding, pediments, entablatures, and pilasters, which comprise a door surround, shall be preserved and maintained. The following standards shall be followed.

1. These features shall be repaired by patching and splicing or by limited replacement with materials matching the original in size, shape, and composition.
2. Door surrounds that are original to the building shall not be removed.
3. If replacement of a feature is required because of its advanced deterioration, the replacement feature shall match the original feature with regard to design, materials, size, placement, and color.
4. If fanlights, sidelights or transoms need to be replaced, the replacement shall match the original glazing with respect to the following:
 - A. Configuration of window panes (size, number and location).
 - B. Characteristics of the glass – clear glass shall be replaced only with clear glass, etc.
 - C. Snap-in mullions shall not be used.
 - D. Depth of reveal of the replacement shall be the same as the original.
5. Door surrounds shall not be added to historic buildings unless based upon documentation and then shall conform strictly to historic appearance and materials.

RECESSED DOORS

There are a couple of examples in Brandon of recessed entries, the showcase windows form corners leading to the door. This design provided for more area for the merchant to display his wares and then enticed the shopper to the door. This recessed area shall be retained. The door shall not be moved to the front of the showcase windows. Likewise, a proposed storefront rehabilitation should include designing the recessed area, if photographs show this configuration to be historic.

DOORS

WINDOW COATINGS OF GLAZED DOORS

Tinting, reflective coatings and opaque window coverings on storefront doors or other doors in the commercial buildings are not allowed as they change the look of the historic glass. However, to protect interior fabrics from ultraviolet rays, clear adhesive filtering film, designed to reduce the destructive effects of ultraviolet light, can be applied to the interior surface of the windows.

COATING ALUMINUM DOORS

Over the years, original wood doors have been replaced with aluminum doors. It is best to replace these doors with those designed to resemble the original doors. However, if it is not possible to install new doors, the aluminum doors can be made more compatible with the historic storefront by painting them a dark color or the trim color. The aluminum must be cleaned, primed with a zinc chromate primer or metal primer, and then painted.

STORM DOORS

Storm doors shall not be installed on commercial doors because they change the appearance of the historic door.

SECURITY DOORS

Exterior security doors are inappropriate in the historic district because they changed the historic appearance of the door. In addition, they tend to give a negative impression of the neighborhood. However, security doors on rear doors that are not in the public view are acceptable. During the installation of security doors on rear entrances, care should be taken to ensure that historic materials are not damaged.

SECURITY GATES THAT COVER THE FACADE

Security gates that cover the façade shall be of the type that fold back during the day and do not hide any of the façade when they are open. The attachment of the gates should not damage any of the historic material of the façade.

AWNINGS

Awnings are used to reduce the effects of the sun and rain on the interior of commercial buildings. The historic design of awnings can also add to the character of a commercial building's façade.

APPROPRIATE AWNINGS AND INSTALLATION

1. Canvas or metal awnings are appropriate for storefronts and upper floor windows. Bubble, concave and convex types of awnings are generally not permitted. Internally lit awnings are also not permitted.
2. On upper floors, awnings shall be installed to fit inside the window trim and should cover only one window, not span a distance to another window. Storefront windows should fit the storefront window area. Awnings should fit the opening, rectangular windows should have shed type awnings, while rounded windows should have curved awnings.
3. The color of the awning should complement the building and its neighbors. The color and pattern should not detract from the appearance of the building or street.
4. Awnings should not be installed over windows which have shutters.
5. Awnings should not cover or conceal significant architectural details.
6. Wooden awnings are appropriate for some styles of buildings and will be approved on a case by case basis.
7. Metal, slat, rigid, plastic, aluminum, cedar or plastic shakes, and brightly colored or glossy awnings are not appropriate in the Brandon Historic District and are not permitted.

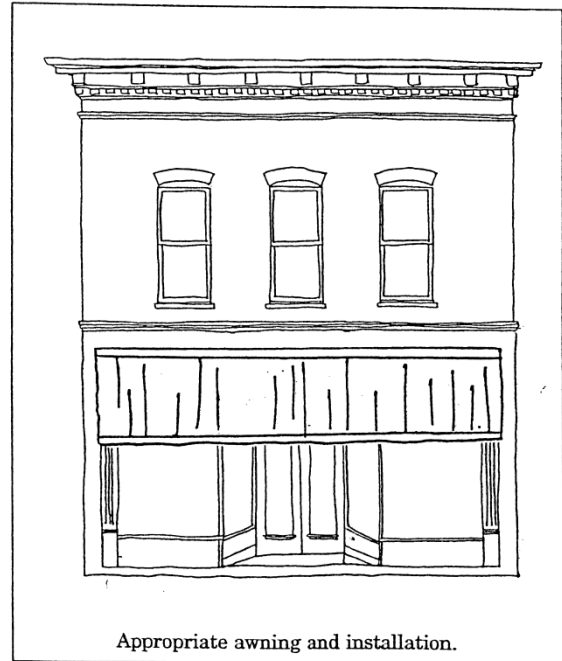

WOOD AND METAL CANOPIES

Wood and metal canopies have been added in recent years to many commercial buildings. These canopies often divide the first floor from the rest of the building, causing the streetscape to appear disjointed. Canopies should be repaired and maintained, but unless there is historic evidence that the wood canopy existed, they shall be replaced only with canvas awnings. See the section on **Awnings**.

LIGHTING

Light fixtures placed on commercial buildings should adhere to the following guidelines:

REPAIR

Every effort shall be made to repair and restore light fixtures that are original to the building.

REPLACEMENT

If replacement is necessary because of advanced deterioration, the replacement shall match the original fixture as closely as possible in design, materials, and location.

If replacement is necessary because the fixture is missing and there is no evidence for the design of the original fixture, the following standards should be considered before choosing a new fixture:

1. light fixtures on buildings in downtown should be as unobtrusive as possible.
2. new light fixtures should be simple in design and be appropriate for the style of the building. Colonial lights are not appropriate and should not be used.
3. awnings should not be internally lit.

MECHANICAL SYSTEMS

HEATING AND AIR CONDITIONING UNITS

1. Mechanical units should be located at the rear of a commercial building and if in view of the public right-of-way, should be screened with shrubbery or low fencing. Roof mounted mechanical units shall be screened from view by parapet walls or other appropriate method.
2. Window air conditioners should be located in windows on the rear or side of a building and shall fit the opening of the lower sash where the lower sash is raised. The sash shall not be removed or replaced, and the opening cannot be made larger.

SATELLITE DISHES

1. Satellite dishes shall not be installed in front yards or in readily visible side yards.
2. Satellite dishes that attach to the building shall be located on side or rear elevations, not on the front. Installation shall not require the removal of any architectural features of the building.

UTILITY METERS

Electric and gas meters should be located on the rear of a building.

GARBAGE COLLECTION

Dumpsters shall be placed on the rear or sides of buildings and shall be screened from the public way by a fence and landscaping.

PARKING LOTS

Parking lots, while a modern necessity, can diminish the historic character of the streetscape. Therefore, parking lots should be designed with buffer zone so that they are as unobtrusive as possible, thus minimizing the effect on the streetscape.

MATERIALS

Materials shall be concrete (natural color, not tinted), exposed aggregate, gravel composed of small stones, or brick (red paving brick). Asphalt is inappropriate for the district and generally is not approved.

LOCATION OF PARKING LOTS

1. parking areas constructed on vacant lots shall be set back four (4) feet from the street right-of-way/property line. These buffer areas shall be landscaped to provide a screen for the parking lot. Interior planting strips must also be added to parking lots.

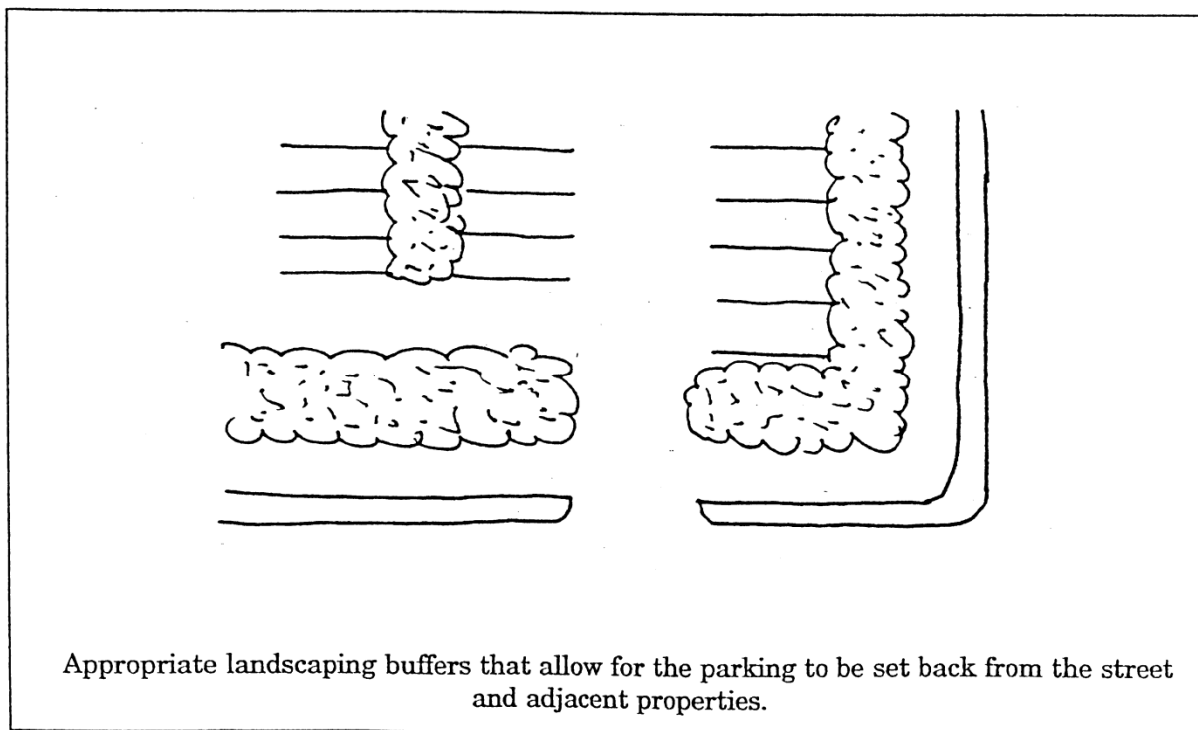

2. the design of a parking area in a vacant lot must incorporate existing trees and provide for their maintenance (i.e. do not pave up to the edge of the tree, provide an area of green space around the tree so that it can survive the impact of the parking lot).

3. lighting of parking areas should be as unobtrusive as possible, should focus down, and not spill over on adjacent buildings.

EXISTING PARKING LOTS

1. existing parking lots shall be maintained and repaired with materials duplicating the existing.

PARKING LOTS

2. previously existing asphalt parking lots can be replaced with bricks or concrete; however, previously existing concrete or brick lots cannot be replaced or covered over with asphalt.

FENCES AND WALLS FOR PARKING LOTS

New fences and walls around parking lots are approvable in the Brandon Historic District if they meet the following standards:

1. The style and design of a new fence shall complement the architectural styles of the building along the street.
2. Structural members, such as posts and horizontal supports, must be placed on the inside of the fence, leaving the “finished” side to face other properties.
3. The following materials are inappropriate for the Brandon Historic District and are not permitted: vinyl, chain link, barbed wire, plastic, metal sheets, board and batten, split rails, post and rail, stockade, bamboo, and chicken wire.
4. Fencing shall be no taller than 3’-6” high and have a pattern with space in between the vertical members in order to be able to see through the fence.
5. Wrought iron and wood picket fences are appropriate for the Brandon Historic District.
6. Wood pickets should not be wider than four (4) inches and be set no farther apart than three (3) inches.
7. Walls shall be no higher than 3’-6” and should be compatible with neighboring walls and buildings.
8. Walls may be constructed of bricks or concrete blocks if the concrete blocks are stuccoed, not simply painted.
9. The following are inappropriate for the Brandon Historic District and are not permitted: un-stuccoed concrete blocks, field stone, rubble stone, or other decorative features, such as concrete balls that are not historically appropriate.

ADDITIONS

Additions can be designed for historic commercial buildings so that there is the least possible loss of historic materials and so that character-defining features are not obscured, damaged, or destroyed. Designs for additions should take into consideration the following standards:

1. Additions shall be located at the rear of the buildings.
2. Additions shall be no taller than the existing building; shorter than the main building is preferable.
3. The shape of the addition shall be compatible with the existing building (i.e. tall and narrow or short and wide). In addition, the roof form should be compatible with the historic building and consistent with contributing roof forms along the street.
4. Foundation height, floors, and eave lines in the addition shall line up with those in the existing building.
5. Windows shall be similar in proportion and size, but need not necessarily duplicate the existing windows exactly. However, the windows shall follow the pattern established on the side of the existing building.
6. Doors shall be similar in proportion and size, but again need not necessarily duplicate the existing doors exactly.
7. Materials used in the addition shall be the same as found on the existing building. Clapboard-sided buildings should have clapboard-sided additions. Additions to brick or stone buildings can be wood frame, however. Roof materials should be the same on both the existing building and the addition.
8. Ornamentation of the addition shall not be more elaborate than the existing building.
9. Additions should be designed in such a way as to be reversible if the addition is removed. It is best to use existing door and window openings to connect the existing building with the addition. It is also best to retain the siding that is covered by the addition, either by covering it with a new siding or using the original siding as a design feature of the new room, instead of removing the original siding.
10. Additions should be designed so that the addition does not appear to be a part of the existing building. This is a difficult concept, because the addition must blend in with the rest of the building, but at the same time be clearly viewed as an addition.
11. Adding an additional story to a building is not permitted, as it completely changes the character of the building.

OUTBUILDINGS



OUTBUILDINGS

Historic outbuildings such as garages, sheds, carports, greenhouses, carriage houses, and stables that contribute to a property's architectural character should be preserved. Rehabilitation of outbuildings should take into consideration the following guidelines:

REPAIR

Every effort should be made to repair the character-defining elements of outbuildings including foundations, siding, steps, roofs, windows, doors, and architectural ornamentation by patching, splicing, consolidating, or otherwise reinforcing existing materials or by limited replacement in kind of extensively deteriorated parts. See **Routine Repair and Maintenance**.

REPLACEMENT

Where replacement is necessary because of advanced deterioration, the replacement materials shall be the same in style, composition, color, and texture as the damaged materials. For more information about replacement of the parts of an outbuilding see **Foundation, Siding, Steps, Roofs, Windows, Doors, and Architectural Ornamentation**.

REPLACING A MISSING OUTBUILDING

When a historic outbuilding has been previously removed, it should be replaced with a new outbuilding designed with pictorial evidence of the historic building. If no such documentary evidence exists, a new design can be developed to be compatible with the main building and other historic outbuildings in the historic district. Please see **New Construction: Outbuildings** for complete information on designing new outbuildings.

SIGNS



SIGNS

The guidelines for signs are broken into two sections defined as – residential, being those areas that were traditionally residential but may now be rezoned for office and commercial uses; and – commercial, being those areas comprised solely of commercial buildings. In addition to the requirements of this section, signs in the Brandon Historic District shall comply with the provisions of the Zoning Ordinance of the City of Brandon provided that where such provisions are in conflict with this section, the requirements of this section shall prevail.

HISTORIC SIGNS

Historic signs, such as painted wall signs and tiled entry floor signs, shall be repaired, preserved and maintained.

STANDARDS FOR BOTH RESIDENTIAL AND COMMERCIAL AREAS

1. Signs shall not conceal any window, door or architectural detail; clutter the building's image; or detract from the unity of the façade, but shall complement the overall design.
2. Sign material shall complement the material of the related building.
3. No façade shall be damaged in the application of signs.
4. When mounting signs on masonry walls, signs should be anchored into the mortar, not the masonry.
5. Signs shall be lit by remote sources, not from within.
6. Signs shall be constructed with traditional materials such as finished wood, glass, copper, or bronze. Signs may be hand carved, sandblasted or painted. Plastic, unfinished wood, plastic letters, foam letters and cardboard are not permitted. Plywood is permitted only if a border is added to the edges of the sign in order to keep the edge from fraying and only if the sign has adequate paint so that it does not appear to be constructed of plywood. Sheet metal is permitted only if it is attached to a board so that it has some depth to it and does not appear flat. Sheet metal must be painted. "Wood foam," a plastic that has the appearance of wood may be used, but must be painted.
7. Sign colors should contrast enough to be easily read, but should blend in with the building and its neighbors. Bright, neon colors such as bright yellow, orange and bright red on white are not permitted.
8. Franchise signs must respect the character of the Brandon Historic District and must be built of traditional materials and be externally lit. There are many cities and communities where franchises have modified their signage for historic areas. Examples can be found in North Carolina, South Carolina, and even Madison, Mississippi.
9. Neon is not acceptable sign material unless it is an existing sign that has achieved significance.
10. The following are not permitted within the Brandon Historic District:
 - A. Banners, pennants, and streamers
 - B. Portable, folding, or similar movable signs
 - C. Signs located on any street or public right-of-way, curb, hydrant, lamp post, tree, barricade, telephone or light pole, other utility pole, public fence, or on a fixture of a fire alarm or police system.

- D. Signs with revolving or rotating beams of light or flashing lights.
- E. Roof mounted signs.

Traditionally Residential Areas – Commercially Zoned Areas Where the Predominant Land Use is Residential

Signs in residential areas should be compatible with the character of the district and should blend in with the character of the buildings on or near which they are placed. A building is permitted one (1) ground-mounted or pole sign and one (1) wall sign. The most appropriate pole sign is a single wood 4x4 with a projecting wood post from which the painted or sandblasted and painted wood sign hangs. Signs shall meet the following standards:

1. Ground or pole-mounted signs shall not exceed eight (8) square feet in area and shall be not taller than (6) feet tall.
2. Wall signs shall not exceed four (4) square feet or six (6) square feet for more than one tenant and shall be placed not taller than six (feet).
3. The design of signs in residential areas should be simple and, while they should be readily visible by their design and color, they should not negatively impact the neighborhood.
4. Ground or pole-mounted signs should be setback from the sidewalk at least five (5) feet and should line up with other signs along the street. Exception: circa signs should be nearer the street/sidewalk.

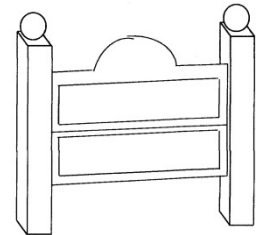

Appropriate ground mounted sign.

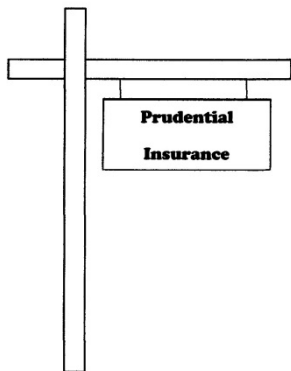

Appropriate pole sign.

5. Signs shall not be attached to roofs or porches and shall not be painted on the walls of residential buildings.
6. Lighting shall be cast from the ground adjacent to the sign and light fixtures shall be as minimal as possible. If a business does not operate at night, it is suggested that lights are not necessary in a residential area.

SIGNS

Commercial Areas – Commercially Zoned Areas where the Predominant Land Use is Commercial

Signs in commercial areas should be compatible with the character of the district and should blend in with the character of the building and its neighborhood. A building with one business is permitted two signs including: a suspended sign, projecting sign, wall, sign, awning sign, or window sign. Signs should meet the following standards:

1. Suspended signs shall be appropriate for the building and should be hung perpendicular to the street, from the bottom of a canopy or balcony. Suspended signs may be hung parallel to the street from the bottom of a canopy or balcony, however perpendicular is preferred. The bottom of the sign shall be nine (9) feet above the sidewalk.
2. Projecting signs shall be of a scale appropriate to the building as determined by the Historic Preservation Commission and shall be hung from the building in an area that does not obscure or damage any architectural features. The brackets for the sign shall be placed in the mortar, not in the brick. The bottom of the sign shall be nine (9) feet above the sidewalk and the sign should project no more than 4 feet from the building.
3. Wall signs can be painted or attached in a number of locations depending on the design of the storefront. The storefront shall be defined as the building face immediately facing the street right of way. Each building will only be allowed only one face to be considered storefront, even if a corner lot, unless otherwise approved by the Historic Preservation Commission. Painted signs on building faces not considered storefront will be considered by the Commission on a case by case basis.

A. On some buildings there is an area above the storefront windows that was designed for a sign. The name of the business can be painted in this area only if the exterior veneer being painted on is stucco or previously painted brick, wood, or similar painted material. Wood or simulated wooden signs may also be appropriate. The size of the sign must be proportional to the building façade and be appropriate for the building style as determined by the Historic Preservation Commission. The material must also be appropriate to the building style and period.



Appropriate wall sign

B. If there is not an area designed for a sign, a sign can be painted on or attached in the area above the storefront (the belt course), but below the second-floor windows. Again, the name of the business can be painted in this area on the appropriate material or a wooden or simulated wooden sign, and, can be attached to the building. The size of the sign must be proportional to the building façade and be appropriate for the building style as determined by the Historic Preservation Commission. The material must also be appropriate to the building style and period.

C. On some commercial buildings that do not have the traditional storefront, there is a space on the wall beside the entrance where a wooden wall sign, no larger than six (6) square feet for a single tenant building or four (4) square feet for each tenant in buildings with more than one tenant, can be placed. A master signage plan must be submitted and approved by the Commission for buildings with multiple tenants before individual tenant signs can be approved.

SIGNS

D. Other instances that do not specifically fit into these descriptions can be considered by the Historic Preservation Commission on a case by case basis.

4. Awning signs shall have the name of the business painted on the front or sides of the awning and the letters shall be no taller than six (6) inches. The color of the letters should complement the color of the awning.
5. Window signs are more easily seen if they are rendered in a light color or gold leafed letters with a dark border. The total area of the sign should not be larger than six (6) square feet.
6. Signs should be lit externally. Internally lit signs are not permitted.
7. Signs should be designed with the architecture of the buildings in mind. They should not be signs of earlier periods such as Colonial-type designs. Lettering should be chosen because it is easy to read.
8. Signs should have no more than three colors that coordinate with the colors of the building. Light colors on a dark background are the easiest to read.
9. The design of any sign must be appropriate to the building and district as determined by the Historic Preservation Commission.

SIGN DEFINITIONS

Awning sign – any sign painted on an awning.

Ground sign – any sign where the entire bottom of the sign is generally in contact with or in close proximity to the ground.

Pole sign – any sign which is supported by a pole or poles and is independent of support from a building.

Projecting sign – any sign affixed to a building or wall where the leading edge extends beyond the building or wall.

Suspended sign – any sign that hangs under a porch, awning or canopy.

Wall sign – any sign painted or attached to the façade.

Window sign – any sign painted on a window or the glass area of a door which is meant to be read from outside the building.

NEW CONSTRUCTION

Residential and Commercial



GENERAL GUIDELINES

Throughout the Brandon Historic District buildings have been lost by acts of nature and by demolition, leaving vacant lots that appear as “holes” in the streetscape. This is especially visible on South College Street and Government Street. New buildings constructed on these lots are called “infill” buildings. The sympathetic design of these infill buildings are of utmost importance because they must harmonize with the character of the neighborhood.

Brandon is an architecturally diverse community and new construction should not be designed to imitate any particular architectural style. The following guidelines are intended to guide design for new construction to ensure that new development is compatible with the existing character of the district. A good example of this concept can be seen at Heartsease Subdivision of West Jasper Street.

The central idea behind good infill is that it should be designed by those buildings around it. If the design of the new façade grows out of its neighbors, it is sure to be compatible. This approach strikes a proper balance between the existing architecture and good contemporary design.

Design principles that should be “borrowed” from neighboring buildings include **emphasis, rhythm, proportion, and scale**. The directional **emphasis** of a building is either vertical – tall with narrow windows and facades, or horizontal – wider than it is tall and it has a low roof.

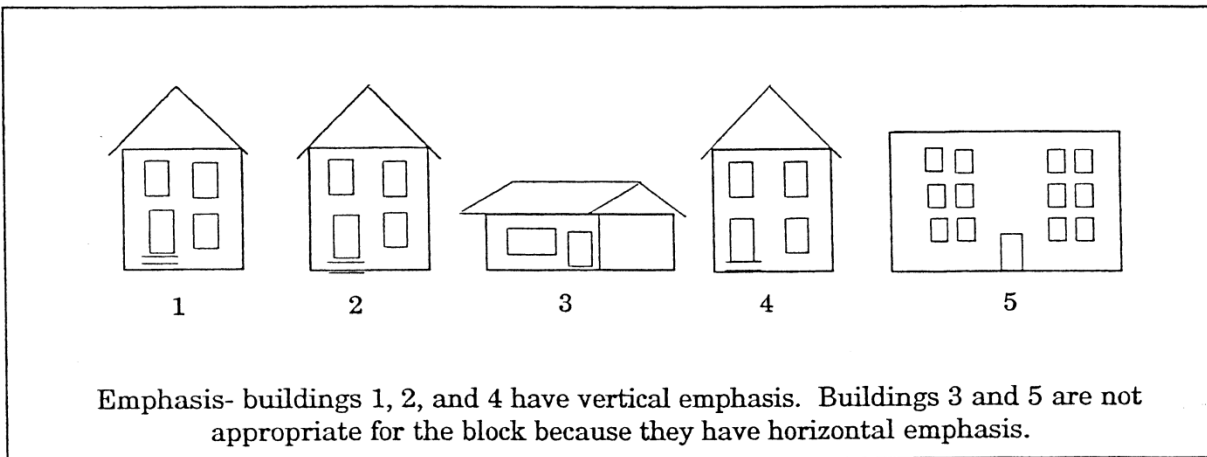

Proportion is the relationship of one dimension to another, usually width to height – a window that is 24” wide and 48” tall has the same proportion as one that is 12” wide and 24” tall, in that both of them have a height that is twice the width. The proportion of facades and their elements should be considered when designing infill buildings.

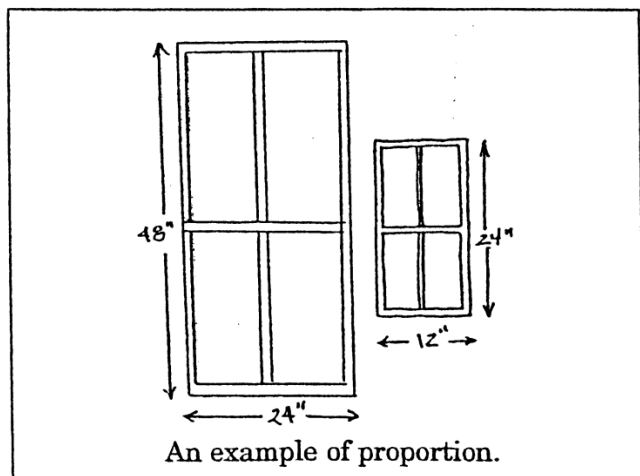

GENERAL GUIDELINES

Rhythm is created by repeating patterns such as regularly spaced windows and doors – window, window, door, etc. An area with houses that are built around the same time may have a stronger rhythmic pattern than a street with houses from many periods, but there will still be a rhythm that should be considered when designing infill.

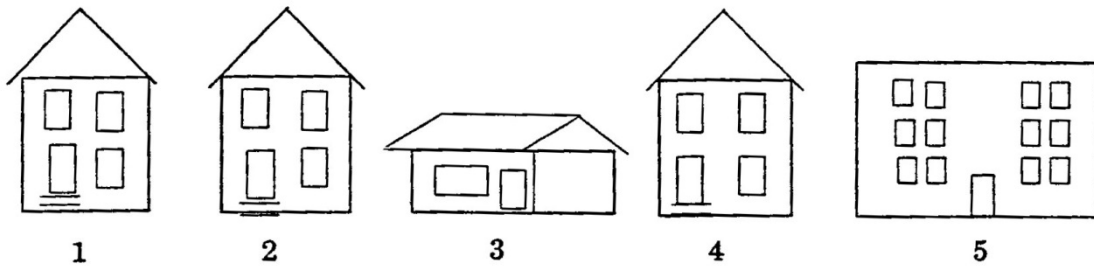

Rhythm- buildings 1, 2, and 4 have similar rhythm because of the window and door placement. Buildings 3 and 5 are out of rhythm because of their size and configuration.

Scale involves the relationship of elements of the building to the whole of the building in their size, height, mass and width. For example, imposing brick columns would fit a large Greek Revival mansion, but will overpower a small one-story frame residence. Likewise, a porch that once had sturdy 6x6 wooden posts to support the roof suddenly appears unstable if the posts are replaced by delicate wrought iron supports. In reality the wrought iron can easily support the roof, but visually they do not appear to be able to do so. It looks flimsy because the supports are out of scale with the porch. New buildings should be in scale with existing buildings and also elements of the new façade itself must be in scale with each other.

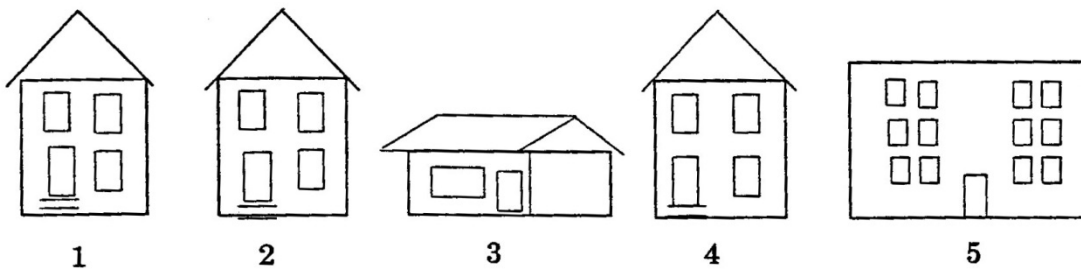

Scale- buildings 3 and 5 are out of scale with buildings 1, 2, and 4 because they differ in size, height, mass and width.

RESIDENTIAL

New residential buildings should be contemporary in design but must be compatible with the historic buildings along the street. In order to meet this requirement, infill residential buildings should be designed using the following standards:

SETBACK, SPACING, AND ORIENTATION

Setbacks (the distance a building is placed on the lot, from the edge of the right-of-way in the historic district are uniform and establish a feeling of cohesion. New buildings shall have setbacks consistent with existing buildings on the street. Spacing is the distance between buildings, essentially the size of the side yards. The spacing of buildings on their lots should be considered as well because this placement helps to establish the rhythm of the streetscape. Infill buildings shall have the same orientation – face the same direction – as existing buildings on the street.

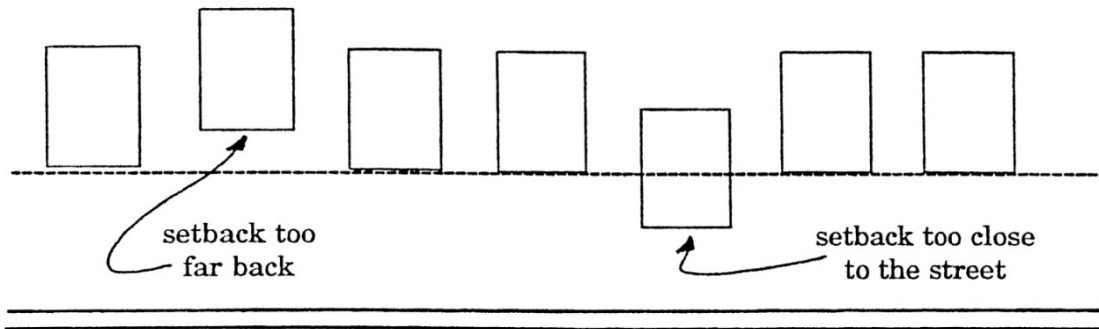

New construction should maintain the same setback as the existing buildings in the block.

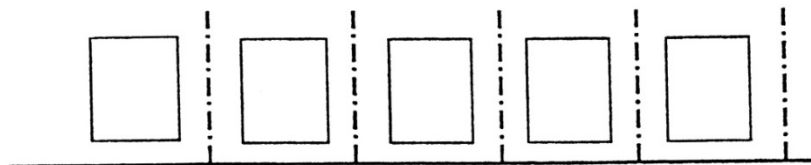

Appropriate spacing (side setbacks and front setbacks).

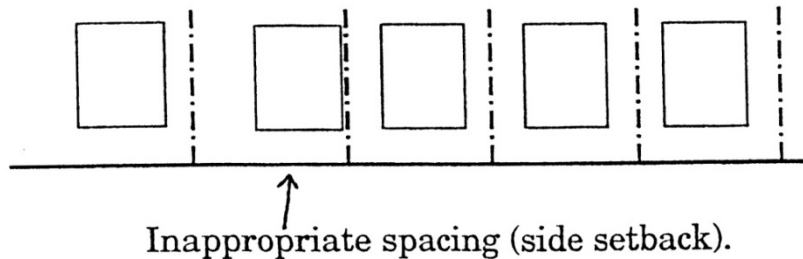

RESIDENTIAL

SIZE AND SHAPE

The size and shape of infill buildings shall be consistent with other buildings on the street with regard to the following areas:

1. **Height** – should be consistent with the existing buildings on the street. Most of the residential buildings in the Brandon Historic District are one, one and a half, or two stories tall. New buildings should be designed to match the height of their neighbors. Floor to ceiling heights should also be maintained.

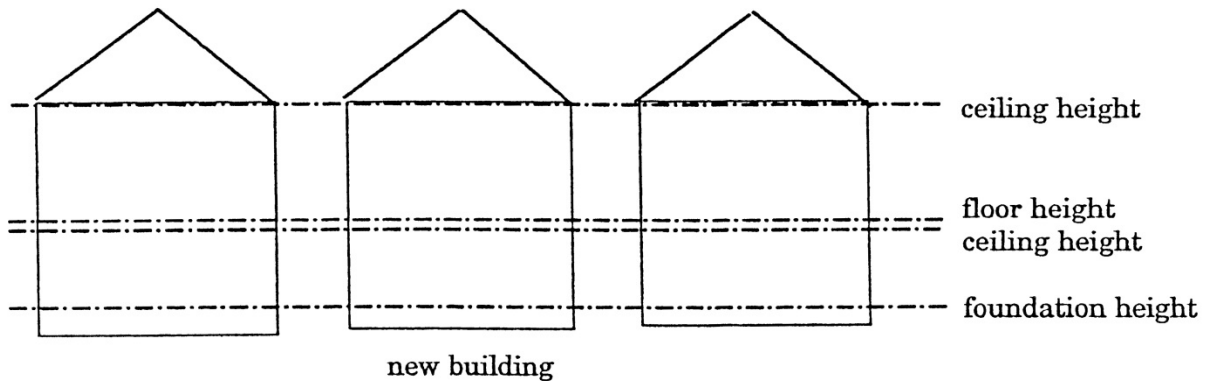

The foundation heights, floor to ceiling heights, and overall building heights of the existing historic buildings should be maintained in the new building.

2. **Proportion** – the new building should match the surrounding building in proportion, being the width to height ratio (tall and narrow or wide and short).

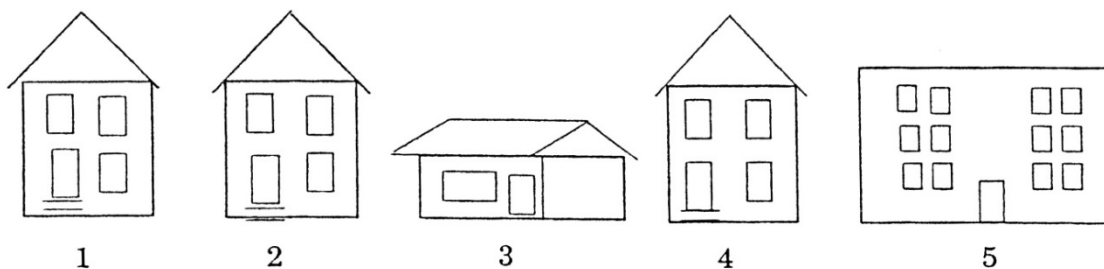

Proportion- buildings 1, 2, and 4 have the same proportions. Buildings 3 and 5 are out of proportion with the adjacent buildings.

3. **Massing** – shape of the new building, how the building's shapes are fitted together, should take into consideration the massing patterns of existing buildings on the street. Massing patterns may be that all of the houses on the street are L-shaped cottages, square two-story boxes, or elaborate Queen Ann residences with different porches, projecting rooms, towers and turrets.

RESIDENTIAL

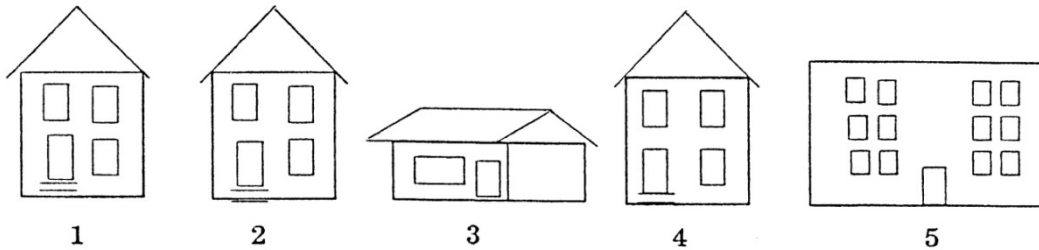

Buildings 1, 2, and 4 have similar massing because of the window and door placement, roof size and shape, etc. Buildings 3 and 5 have inappropriate massing.

4. **Roof shape and pitch** – roof shape and pitch should be consistent with that of existing buildings. Most roofs in Brandon’s historic districts are gables or hips. A limited number of flat, mansard, and gambrel roofs can also be found, but should not be the design for infill buildings. Roofs should also orient in the same direction as existing roofs, for example if the roofs along the street are built with the gable end to the street, then the new building’s roof should also have the gable end to the street.

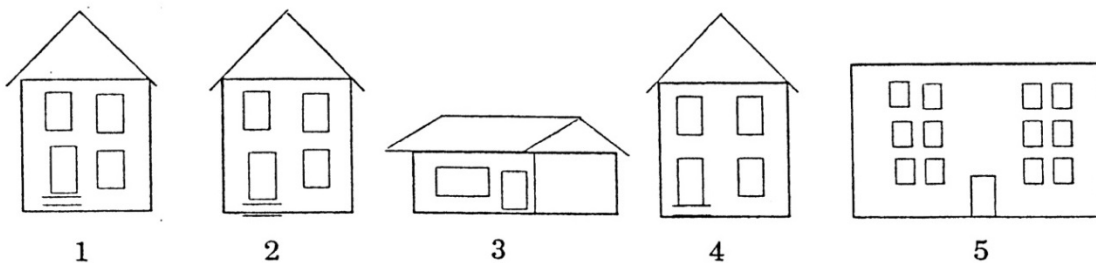

Buildings 1, 2, and 4 have the same roof shape and pitch. Building 3 has an inappropriate pitch and building 5 has an inappropriate shape.

5. **Porches** – on an infill building the porch should be designed to be consistent with the height and depth of the adjoining porches. The roof shall be a gable, hip, or shed, depending on existing porches. Porch columns and railings should be simple in design, match the material of existing porch columns and railings, and be of the appropriate scale for the porch and the house in general.

6. **Foundation height** – historic buildings were built on conventional foundations, on piers of two to three feet. New construction should have similar foundation heights. Slab foundations or at-grade foundations are not appropriate for new construction in the residential areas (see illustration under **Height**).

RESIDENTIAL

7. **Windows and doors** – the width, height, number and spacing of windows and doors should be compatible with neighboring buildings.



The existing buildings have vertical windows. The infill building has horizontal windows which are inappropriate because of their size and shape.

ARCHITECTURAL COMPONENTS

Architectural design, components such as cornices, lintels, chimneys, towers and turrets should be included in the design of infill buildings and be compatible with neighboring buildings. These design components should not exactly duplicate historic examples. Nor should components from different styles be used in conjunction on the same building. For example, the design of an Italianate cornice, a Craftsman window, and a Queen Anne turret should not be extracted from different buildings and placed on an infill building because it is believed that it is “historic” design and therefore would be appropriate to the district.

MATERIALS

Materials for new construction shall meet the following standards:

1. **Roofing materials** should be consistent with that of neighboring buildings. Appropriate materials are slate, pressed metal, and fiberglass shingles in dark colors.
2. **Chimneys** should be built using brick that is similar in color to other chimneys on the street. Wood-sided chimneys are not acceptable.
3. **Siding** should be that which is predominant along the street. Brick siding should be similar in color to other brick buildings. Wood siding should be beveled or lap siding 5” maximum exposure. Concrete “clapboard” is acceptable if it meets the correct dimensions and is painted. Stucco should be actual stucco, not synthetic stucco (EIFS). However, synthetic stucco on upper stories is approvable, but not recommended because the material is untested for length of satisfactory lifespan. Sidings that are not appropriate in the Brandon Historic District are metal, artificial brick or stone, artificial siding (plastic, aluminum, and vinyl), oversized brick, concrete block, plate glass walls, vertical siding, wide panel siding (8” or greater), diagonal siding, and plywood panels.

RESIDENTIAL

4. **Steps and railings** should be consistent with the neighboring buildings. Wood steps and wood railings or simple wrought iron railings are the most prevalent in the historic district.
5. **Foundations** in the historic district are mostly conventional on brick piers. New foundations can be concrete block if they are faced with brick. The curtain wall (under-skirting) should follow the guidelines for **crawl space enclosures**.
6. **Windows** should be wood, however vinyl-clad windows are acceptable.
7. **Doors** on the front façades should be wood.

ARCHITECTURAL DETAILING

The details on new buildings should be compatible in scale with those used in the area. Cornices, lintels, arches, balustrades, chimneys, shutters, and column styles that are sympathetic with adjacent existing details will have a unifying effect. Duplication of details is not necessary.

WINDOWS

Windows should match historic windows on adjacent buildings in size and shape. The configuration of the windows can vary from historic windows on the street. For example, they can be one-over-two, but if these light arrangements are chosen, the sashes should be actual divided lights, not snap-in mullions.

COLOR

Color on new construction should be compatible with neighboring buildings.

DRIVEWAYS

Driveways for new residences should follow the guidelines for new **driveways**.

LANDSCAPING

When preparing a lot for a new building, the existing landscaping should be taken into consideration. Trees 6" in diameter or larger shall not be cut down without the approval of the Preservation Commission. The addition of trees and plantings is encouraged around new construction. For more information please see **Landscaping**.

COMMERCIAL

There are two distinct types of commercial infill buildings that are possible in the Brandon Historic District. The first type is that which will occupy a space in the central business district along Government Street and a block off of Government Street in either direction. Within this area are commercial buildings with traditional storefronts. The second type is the commercial building constructed on what was historically a residential lot or constructed more recently. These generally will not have traditional storefronts. While the guidelines for these commercial building types are the same for many features, because of the unique nature of the traditional storefront and the need to maintain a stricter design, the two are treated separately here.

TRADITIONAL STOREFRONT COMMERCIAL

Traditional storefront buildings are those one, two or taller commercial buildings that sit immediately next to neighboring buildings, with no side setback. The front setbacks are exactly the same and the first floors all maintain traditional storefront windows and doors. The design of infill buildings in these areas is critical in order to maintain a flow from one building to the next creating continuous display along the street. The similar storefronts – window/door/window – create a rhythm that gives the street an organized and coordinated appearance. Historic downtown buildings were designed to relate to one another, to complement each other, and to be visually tied together. This creates a unified look along the streetscape and makes the pedestrian feel more comfortable when moving from store to store. The following standards must be met when designing new infill in these areas:

SETBACK, SPACING, AND ORIENTATION

The setback (the distance that a building is placed on the lot from the edge of the right-of-way) of an infill building should be exactly that of the neighboring historic building. As a general rule, there is no space between buildings in this area. This spacing should be maintained with the new building. In addition, infill buildings shall have the same orientation – face the same direction – as existing buildings on the street.

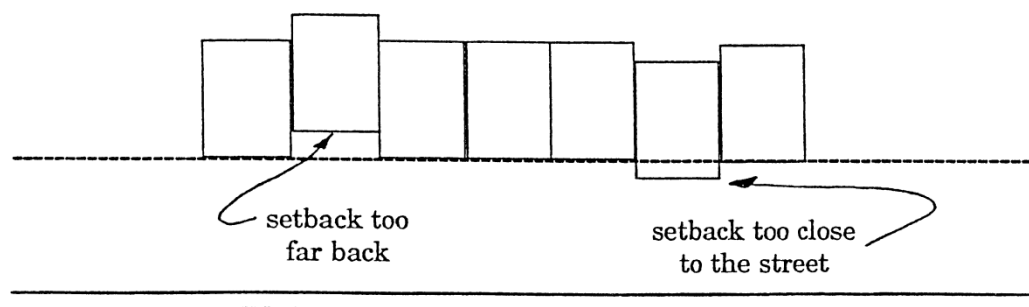

New construction should maintain the same setback as the existing buildings in the block.

COMMERCIAL

SIZE AND SHAPE

The size and shape of infill buildings shall be consistent with other buildings on the street with regard to the following areas:

1. **Height** – should be consistent with the existing buildings on the street. Most of the commercial buildings in the district are one or two stories tall. New buildings should be designed to be consistent with the height of their neighbors. It is very important that floor to ceiling heights be maintained.

2. **Proportion** – the new building should match the surrounding buildings in proportion, being the width to height ratio (tall and narrow). If a new building is proposed for a double lot, one where two buildings originally stood,

the new building should be designed to appear as two tall buildings, not one horizontal building.

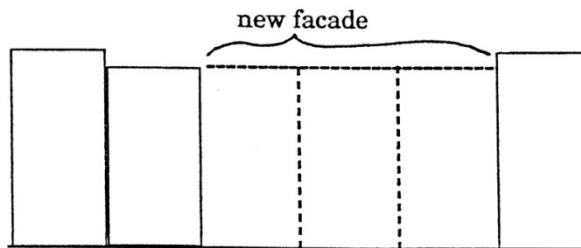

If the site for a new commercial building is large, the mass of the facade should be broken into a number of smaller bays.

3. **Massing** – the shape of the new building, how the building's shapes are fitted together, should take into consideration the massing patterns of existing buildings on the street. The storefront should be designed with similar dimensions as historic examples.

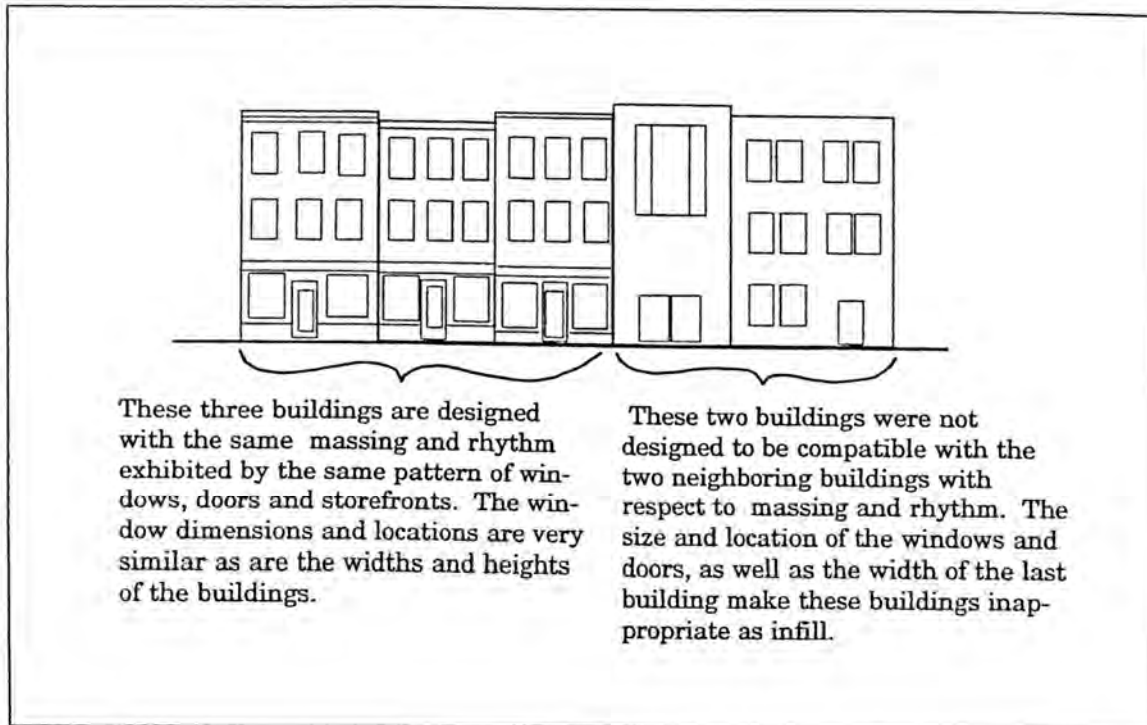

COMMERCIAL

4. **Roof shape and pitch** – the roof should be a flat roof or a sloped roof hidden behind a parapet.

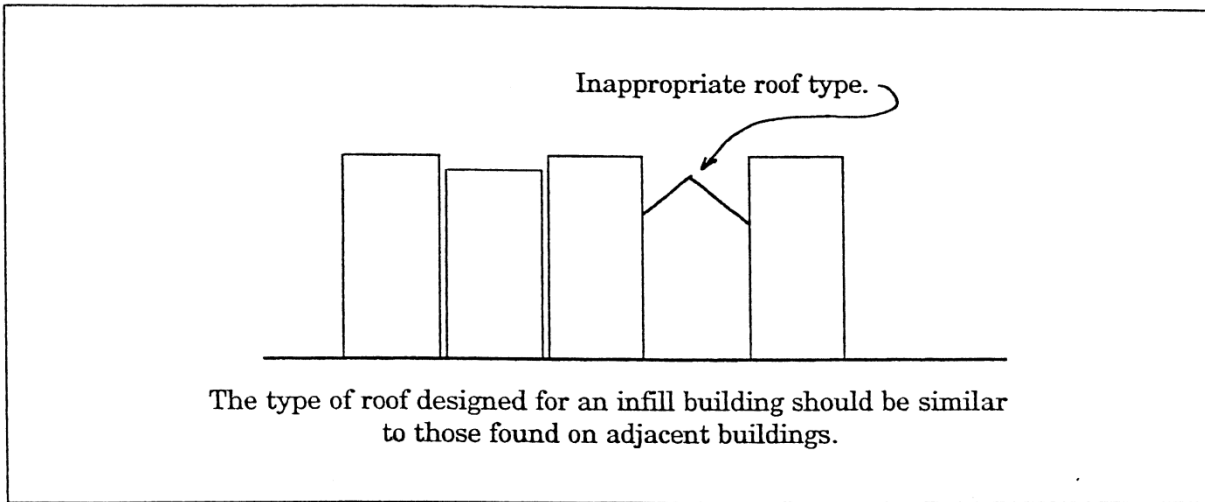

5. **Balconies** – there are examples of historic balconies in Downtown Brandon. If a balcony is designed for an infill building, it should be designed to match existing balconies. Railings should be simple in design, match the material of existing railings, and be of the appropriate scale for the balcony and the building in general.

6. **Wood canopies and canvas awnings** – wood canopies have been added in recent years to many buildings in downtown. These canopies often divide the first floor from the rest of the building, causing the streetscape to appear disjointed. Wood canopies are not appropriate for the new buildings because they perpetuate this problem. Canvas awnings that cover the storefront area are recommended and encouraged as a way to provide protection from the elements for pedestrians. See the section on **Awnings**.

7. **Foundation height** – the foundation height of the new building should be at grade.

ARCHITECTURAL COMPONENTS

Architectural design components such as parapets, cornices, lintels, cast iron pilasters, and window hoods should be included in the design of infill buildings and be compatible with neighboring buildings. These design components should not exactly duplicate historic examples. Nor should components from different styles be used in conjunction on the same building. For example, the design of an Italianate cornice, a Craftsman window, and a Queen Anne turret should not be extracted from different buildings and placed on the infill building because it is believed that is “historic” design and therefore will be appropriate to the district.

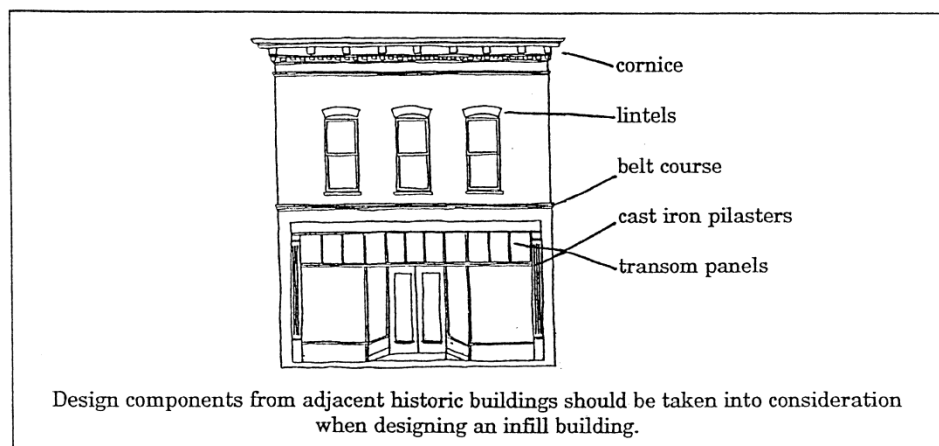

COMMERCIAL

MATERIALS

Materials for new construction shall meet the following standards:

1. **Roofing** materials should be consistent with that of neighboring buildings. Appropriate materials are slate, pressed metal, standing seam, fiberglass shingles in dark colors, and new rubber roofing where hidden behind a parapet.
2. **Siding** should be brick and should be similar to other brick buildings. Sidings that are not appropriate in this part of the district are metal, artificial brick or stone, artificial siding (plastic, aluminum and vinyl), over-sized brick, concrete block, plate glass walls, or wood siding of any kind.
3. **Windows** should be wood.
4. **Doors** should be wood.

ARCHITECTURAL DETAILING

The details on new buildings should be compatible in scale with those used in the area. Cornices, lintel, arches, balustrades, chimneys, shutters, and column styles that are sympathetic with adjacent existing details will have a unifying effect. Duplication of details is not necessary.

WINDOWS

Windows on the upper floor should match historic windows on adjacent building in size, shape, number and location. They should be single, wood, double-hung windows. The upper windows and their placement help to establish a rhythm down the street. The configuration of the windows can be one-over-one; they do not have to be six-over-six or two-over-two, but if multi-light arrangements are chosen, they must be true divided lights, not snap in mullions.

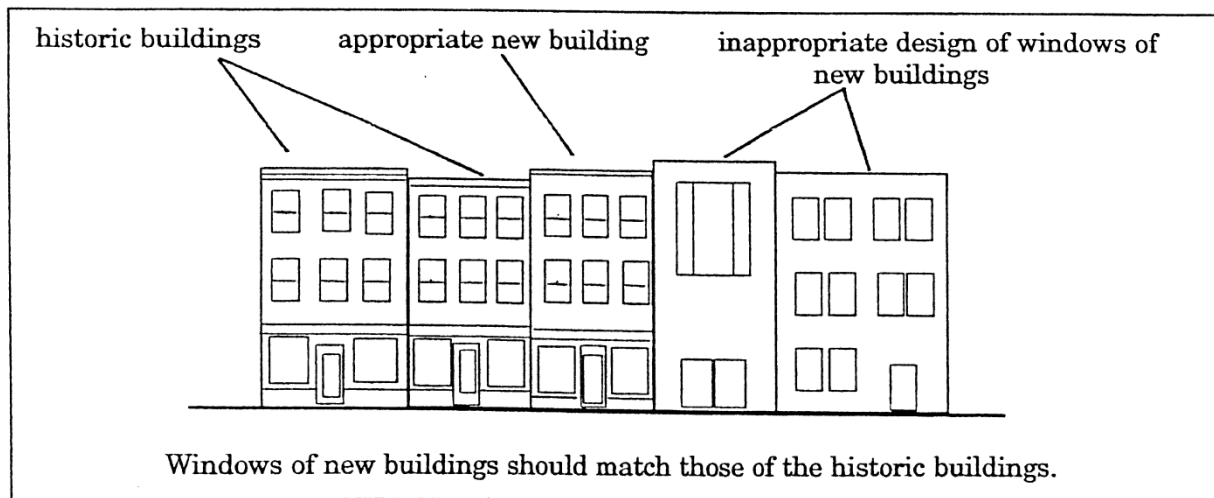

COMMERCIAL

STOREFRONT

The storefront should be designed with the same components as the historic storefront. Those components are the piers on either side of the display windows, the display windows with wooden or brick bulkheads underneath, the door which is a single or double-leaf door made up mostly of glass, and the transom panel across the display window and door. A cornice that runs across the top of the storefront can also be added.

SIGNS

Please refer to **Signs**.

COLOR

Colors on new commercial infill should be compatible with the neighboring buildings.

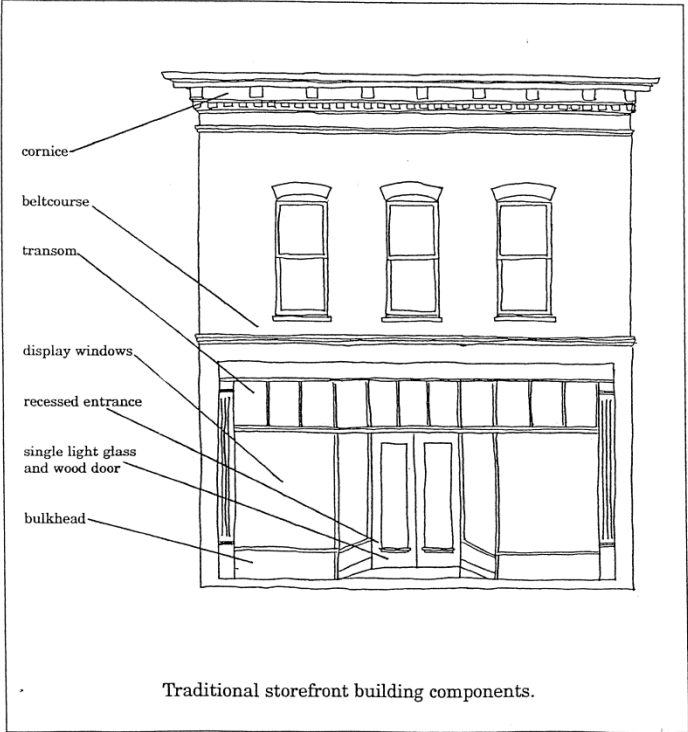

OTHER COMMERCIAL BUILDINGS

The design for commercial buildings proposed to be constructed on what were historically residential lots is treated differently than traditional storefront commercial building. It is more difficult to design this type of commercial building because it must blend into a neighborhood that may have historic residences as well as commercial buildings. The new design must take into consideration the characteristics of both and blend old and new at the same time. The following standards should be observed:

SETBACK, SPACING, AND ORIENTATION

Setbacks (the distance a building is placed on the lot from the edge of the right-of-way) in the Brandon Historic District are uniform and establish a feeling of cohesion. New buildings shall have setbacks consistent existing buildings on the street. Spacing is the distance between buildings, essentially the size of the side yards. The spacing of buildings on their lots should be considered as well because this placement helps to establish the rhythm of the streetscape. Infill buildings shall also have the same orientation – face the same direction – as existing buildings on the street.

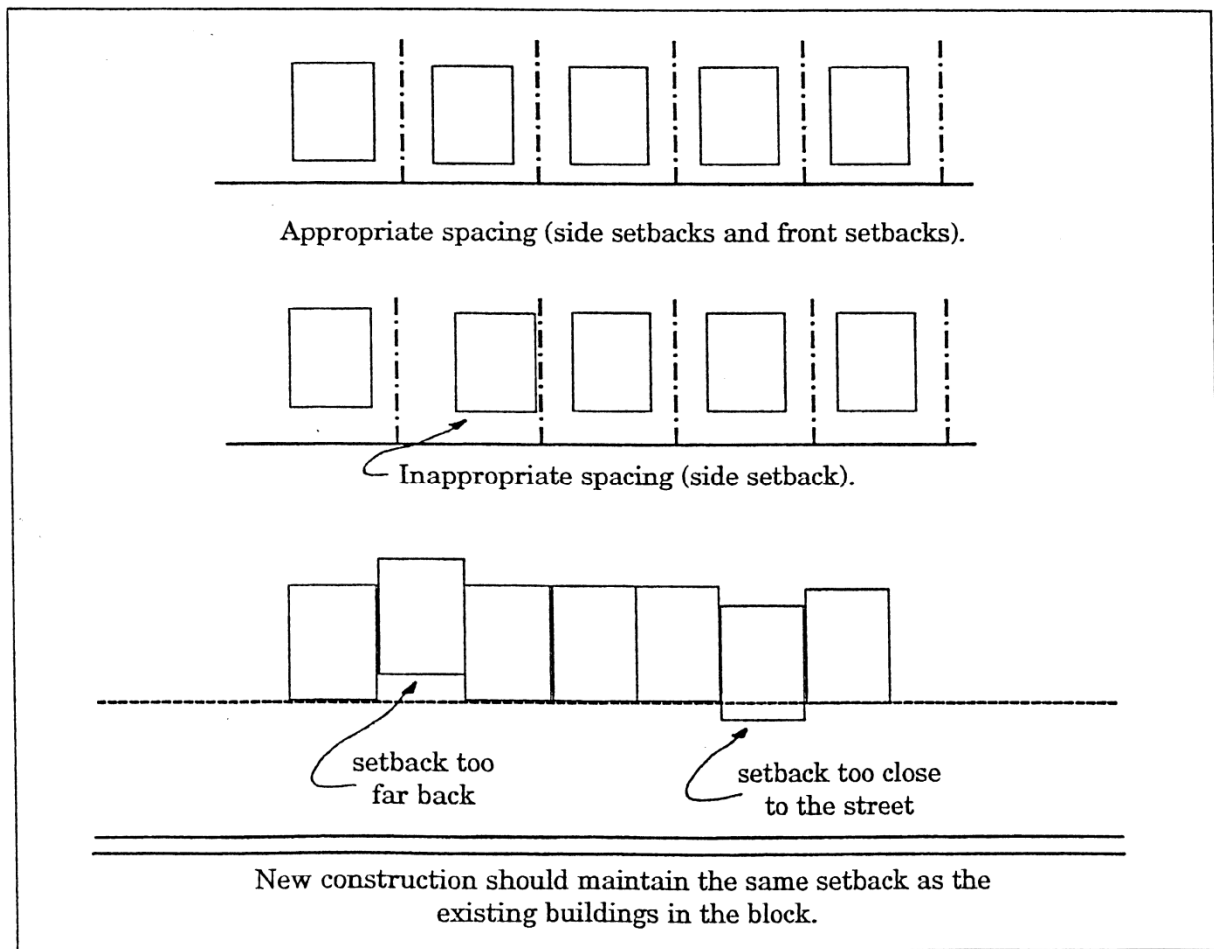

COMMERCIAL

SIZE AND SHAPE

The size and shape of the infill commercial buildings shall be consistent with other buildings on the street with regard to the following areas:

1. **Height**- should be consistent with the existing buildings on the street. New buildings should be designed to match the height of their neighbors. Floor to ceiling heights should be designed to match the height of their neighbors. Floor to ceiling heights should be also maintained.

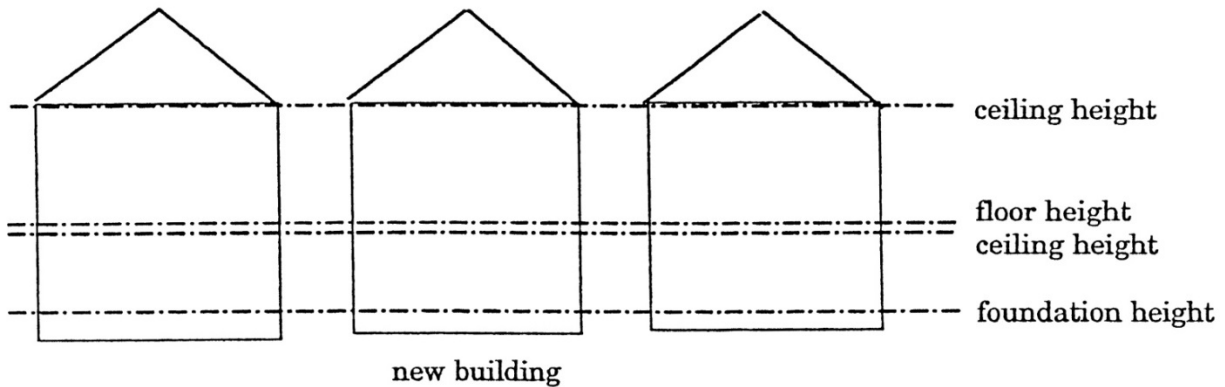

The foundation heights, floor to ceiling heights, and overall building heights of the existing historic buildings should be maintained in the new building.

2. **Proportion** – the new building should match the surrounding buildings in proportion, being the width to height ratio (tall and narrow or wide and short).

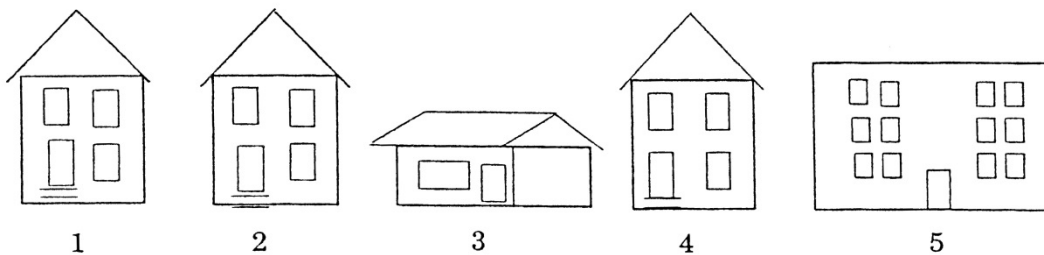

Proportion- buildings 1, 2, and 4 have the same proportions. Buildings 3 and 5 are out of proportion with the adjacent buildings.

3.

Massing – the shape of the new building, how the building's shapes are fitted together, should take into consideration the massing patterns of existing buildings on the street.

COMMERCIAL

4. **Roof shape and pitch** – roof shape and pitch should be consistent with that of existing buildings along the street. Roofs should also orient in the same direction as existing roofs. For example, if the roofs along the street are built with the gable end to the street, then the new building’s roof should also have the gable end to the street.

5. **Porches and porticos** – on an infill building the porch or portico should be designed to be consistent with the height and depth of the adjoining porches. The roof shall be a gable, hip, or shed, depending on existing porches. Porch columns and railings should be simple in design, match the material of existing porch columns and railings, and be of the appropriate scale for the porch and the house in general.

6. **Foundation height** – historic buildings were built on conventional foundations, on piers of two to three feet. New construction should have similar foundation heights. Slab foundations or at-grade foundations are not appropriate for new construction in the residential areas unless the adjacent building is a historic building with an at grade foundation.

ARCHITECTURAL COMPONENTS

Architectural design components such as cornices, lintels, chimneys, parapets, and window hoods should be included in the design of infill buildings and be compatible with neighboring buildings. These design components should not exactly duplicate historic examples. Nor should components from different styles be used in conjunction on the same building. For example, the design of an Italianate cornice, a Craftsman window, and a Queen Anne turret should not be extracted from different buildings and placed on the infill building because it is believed that is “historic” design and therefore will not be appropriate in the Brandon Historic District.

MATERIALS

Materials for new construction shall meet the following standards:

1. **Roofing materials** should be consistent with that of neighboring buildings. Appropriate materials are slate, pressed metal, and fiberglass shingles in dark colors. Rubber roofing can be used on roofs that are hidden behind parapet walls.

2. **Chimneys** should be built using brick that is similar in color to other chimneys on the street. Wood-sided chimneys are not acceptable.

3. **Siding** should be that which is predominant along the street. Brick siding should be similar in color to other brick buildings. Wood siding should be beveled clapboard of four to six inches. Concrete “clapboard” is acceptable if it meets the correct dimensions and is painted. Stucco should be actual stucco, not synthetic stucco (EIFS). However, synthetic stucco on upper stories is approvable, but not recommended because the material is untested for length of satisfactory lifespan. Sidings that are not appropriate in the Brandon Historic District are metal, artificial brick or stone, artificial siding (plastic, aluminum, and vinyl), oversized brick, concrete block, plate glass walls, vertical siding, wide panel siding (8” or greater), diagonal siding, and plywood panels or other panels routed to look like clapboard.

4. **Steps and railings** should be consistent with the neighboring buildings. Wood steps and wood railings or simple wrought iron railings are the most prevalent in the historic district.

5. **Foundations** in the historic district are mostly brick. New foundations can be concrete block if they are faced with brick. The curtain wall (under-skirting) should follow the guidelines for crawl space enclosures.

COMMERCIAL

6. **Windows** should be wood however vinyl-clad windows are acceptable for one-over-one windows.

7. **Doors** on the front elevation should be wood.

ARCHITECTURAL DETAILING

The details on new buildings should be compatible in scale with those used in the area. Cornices, lintels, arches, balustrades, chimneys, shutters, and column styles that are sympathetic with adjacent existing details will have a unifying effect. Duplication of details is not necessary.

WINDOWS

Windows should match historic windows on adjacent buildings in size and shape. The configuration of the windows can vary from historic windows on the street. For example, they can be one-over-two, but if these light arrangements are chosen, the sashes should be actual divided lights, not snap-in mullions.

COLOR

Color on new construction should be compatible with neighboring buildings.

SIGNS

Please see the section on **signs**.

DRIVEWAYS AND PARKING LOTS

Driveways for new residences should follow the guidelines for new **driveways and parking lots**.

LANDSCAPING

When preparing a lot for a new building, the existing landscaping should be taken into consideration. Trees 6" in diameter or larger shall not be cut down without the approval of the Preservation Commission. The addition of trees and plantings is encouraged around new construction. For more information please see **Landscaping**.

OUTBUILDINGS

New outbuildings such as garages, carports, and storage sheds can be designed and sited to blend with the main building and neighboring buildings if the design mimics them with regard to materials, shape, and features. The following standards should be met when designing a new outbuilding in the Brandon Historic District.

LOCATION

A new garage or shed should be located in the rear yard of the building and should not be attached to the house.

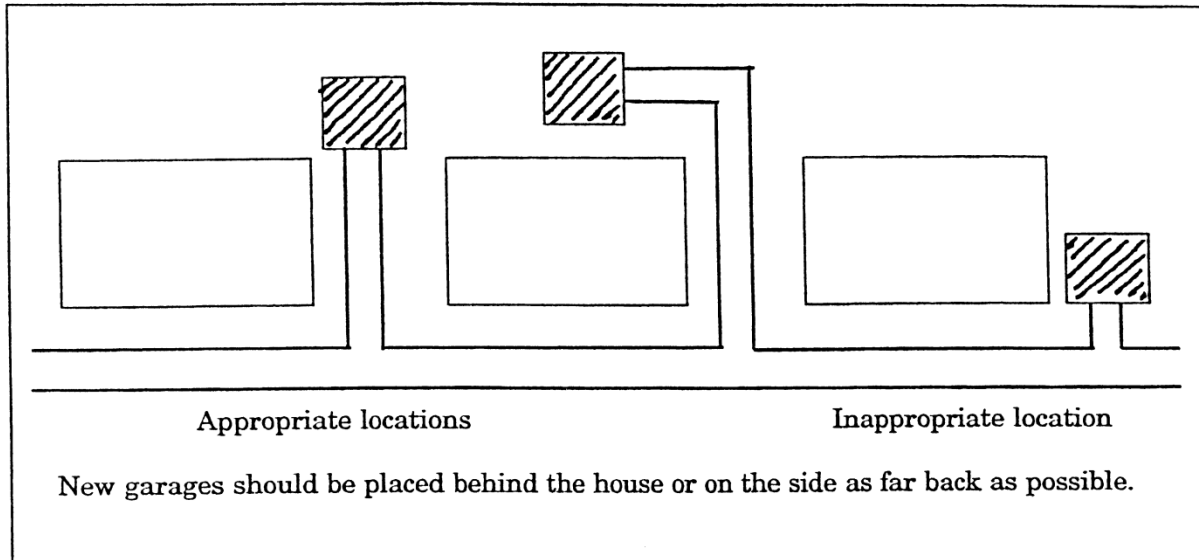

SIZE AND SHAPE

New garages and sheds should be smaller in scale than the existing building. The design should be simple, but should take into consideration the design of the main building and incorporate its roof shape and general character. If there are historic garages in the neighborhood of the same period as the main house, these may yield design ideas for the new building.

MATERIALS

The materials used in the new garage or shed design should be similar and compatible with materials of the new house. Sidings that are not appropriate in the Brandon Historic District are metal, artificial brick or stone, oversized brick, concrete block, plate glass walls, vertical siding, board and batten, wide lap siding (8" or greater), diagonal siding and plywood panels or other panels routed to look like clapboard. If the new building is not readily visible from the street vinyl siding can be used. Garage doors should be wood or multi-light glass doors, however they can be vinyl or metal if they are of the paneled type, not the flush type, and are not aluminum in color.

COLOR

The color of new outbuildings should complement the main building and the neighboring buildings.

HANDICAP ACCESS AND FIRE ESCAPES



RAMPS AND ESCAPES

HANDICAP ACCESS RAMP

In order to provide access to historic buildings for disabled persons it is often necessary to make modifications to the buildings and grounds. These modifications must be carefully planned and undertaken so that they do not result in the loss of character-defining spaces, features and finishes. The goal is to provide the highest level of access with the lowest level of impact. The design of the access ramp must not obscure, radically change, damage or destroy features. The design of new access ramps should meet the following standards:

1. Ramps should not be installed at the rear or side of a building and should be of a simple design made of wood. The balustrades and handrails should be simple square design and should be painted to match the color of the porch railing or the body paint color.
2. The ramp should be landscaped with low shrubbery to help screen it from view.

FIRE ESCAPES

1. Fire escapes should be placed where they are not easily seen from the street, such as on the rear of the building.
2. Fire escapes should be painted to match the color of the building.

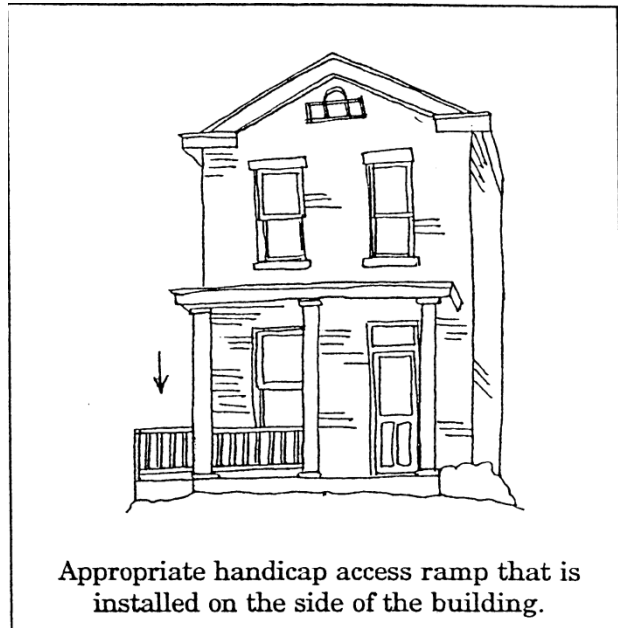

**OTHER ISSUES THAT REQUIRE A
CERTIFICATE OF
APPROPRIATENESS**

RELOCATION

DEMOLITION

SECURING VACANT BUILDINGS

RELOCATION

MOVING A BUILDING INTO THE DISTRICT

A building may be moved into the district to fill in a vacant lot if the building fits the requirements for new construction. The building must be compatible with the district with regard to style, height, scale, massing, material, and texture. The building must be sited on the lot at the same setback as other historic buildings on the street. More information can be found in the section on **New Construction**.

MOVING A BUILDING OUT OF THE DISTRICT

A building may be moved out of the district as a last resort to demolition. Refer to the **Demolition** section.

DEMOLITION

The demolition of a building that is a contributing resource in the Brandon Historic District has a negative impact on the district. The removal of a historically and/or architecturally significant building diminishes the continuity of the streetscape and is detrimental to the promotion of Brandon's historic, aesthetic and cultural heritage. Therefore, there are strict guidelines for the review of demolition permits.

When considering an application for the demolition of a landmark or a resource within the historic district, the following shall be considered:

1. The Commission shall consider the individual architectural, cultural, and/or historical significance of the resource.
2. The Commission shall consider the importance or contribution of the resource to the architectural character of the district.
3. The Commission shall consider the importance or contribution of the resource to neighboring property values.
4. The Commission shall consider the difficulty or impossibility of reproducing such a resource because of its texture, design, material, or detail.

Once a Certificate of Appropriateness application for demolition is received, the Brandon Historic Preservation Commission will assess the property for its significance. This assessment shall be based on the individual architectural, cultural and/or historical significance of the building and its contribution to the architectural character of the historic district. The Commission shall return its determination, after gathering appropriate information about the resource, to the property owner. The Commission may request a stay for 60 days to continue researching for other options.

Should the Commission approve demolition, the applicant must do the following before receiving a demolition permit other any other permits:

1. The applicant must seek approval of replacement plans from the Commission.
2. Plans must include, but shall not be restricted to, project concept, preliminary elevations and site plans, and completed working drawings for at least the foundation plan which will enable the applicant to receive a permit for foundation construction.
3. Applicant must provide financial proof of his ability to complete the project.
4. A demolition permit shall not be issued until all plans for the site have received approval from all appropriate city boards, commission, departments, and agencies.

Should a demolition permit be granted for the building within the Brandon Historic District, the following standards must also be met:

1. Prior to demolition, photographic documentation of the building (interior and exterior) and its grounds shall be undertaken by the Commission.
2. The Commission shall discuss with the property owner the disposition of any architectural features (interior and exterior) to ensure that important features are salvaged and retained.
3. Any large trees or other important landscape features shall be protected during the demolition.
4. If the site is to remain vacant for more than 30 days, it shall be cleared of debris and planted in grass.

SECURING VACANT BUILDINGS

Buildings in the Brandon Historic District that have the potential for being vacant for an extended period of time should be secured to protect them from vandals and doors and the elements. Plywood panels should be secured over windows and doors and should fit inside the window and door frame, not be attached to the outside of the frame. These panels should be painted, preferably the trim or body color of the building. The yard should be cut on a regular basis and falling limbs or trees should be removed. If the roof is in need of repair, it should be protected with a temporary covering until repairs can be made.

APPENDIX



Adaptive Use	The process of converting a building to a use other than that for which it was designed.
Addition	New construction added to an existing building.
Amenity	A building, object area or landscape feature that makes an aesthetic contribution to the environment, rather than one that is purely utilitarian.
Antiquities Act	The Antiquities Act of 1972 was enacted to locate, protect, and preserve sites, objects, buildings, shipwrecks and locations of historical archeological or architectural interest in the state. The approval of the Mississippi Department of Archives and History is required for the transfer of or construction activities on state, county or municipal lands or water which may affect objects, buildings, shipwrecks, and locations of historical, archeological, or architectural interest.
Arch	A means of spanning an opening by use of small units of masonry. Typically, a curved structural element which spans an opening and supports weight from above.
Awning	A roof-like covering, generally of canvas, over a window or to provide protection from the sun or rain.
Balustrade	A series of balusters, or posts, with at top and bottom rail, as along a staircase.
Bay	An opening on a façade such as a door or window.
Beaded Board	A siding of narrow boards with beads run between boards, usually used on exterior porch ceilings.
Bond	The pattern in which bricks are laid to increase the strength and enhance the design.
Bracket	A small carved or sawn wooden projecting element which supports a horizontal member such as a cornice.
Capital	The upper portion of a column or pilaster.
Casement window	A window that is hinged on the side and opens outward.
Casing	The exposed trim molding, framing, or lining around a door or window; may be flat or molded.
Certificate of Appropriateness-	A document evidencing the approval of the Brandon Historic Preservation Commission for work in the Brandon Historic District proposed by the applicant.
Certified Local Government (CLG) –	A federal program authorized by the National Preservation Act Amendment of 1980 for the participation of local governments in a federal/state/local government preservation partnership. The federal law directs the State Historic Preservation Officer (SHPO) and Department of Interior to certify local governments to participate in this partnership.

GLOSSARY

Clapboard	Narrow siding consisting of overlapping horizontal boards, usually thicker at one edge than the other.
Column	A vertical support, usually supporting a horizontal member or roof above.
Contributing Building	A building that is essential to the district's sense of place and that maintains the architectural and historic significance of the district.
Cornerboard	A vertical strip of wood placed at the corners of a frame building to terminate the wood siding and give the corner a finished appearance.
Cornice	A projecting ornamental molding along the top of a wall, window, or door.
Cultural Resource	A building, structure, site, object or document that is of significance in American history, architecture, archeology or culture.
Demolition by Neglect	The destruction of a building caused by abandonment or lack of maintenance.
Dentil	Small square blocks closely spaced to decorate a cornice.
Design Guidelines	Criteria developed by preservation commissions to identify design concerns in an area and to help property owners ensure that rehabilitation and new construction respect the character of designated buildings or districts.
Dormer	A window that projects through the slope of the roof that is sheltered by its own small roof.
Double-hung window	A window with two sashes, one sliding vertically over the other.
Eave	The edge of a roof that projects beyond the face of a wall.
Elevation	The external face of a building or a drawing of a building façade or objects, without an allowance for perspective. An elevation drawing will be in a fixed proportion to the measurement on the actual building.
Façade	The primary wall or face of a building.
Fanlight	A semicircle window over a door or window with radial bars in the form of an open fan.
Fascia	The horizontal board that covers the ends of rafters.
Fenestration	The arrangement of openings, including windows and doors in a building.
Flashing	A sheet, usually of metal, used to make an intersection of materials weather tight.
Frieze	A horizontal band located beneath the cornice at the junction of the exterior wall and roof eaves.
Gable	The triangular section of a wall that carries a pitched roof.
Grade	The ground level at the exterior walls of a building.

GLOSSARY

Hipped Roof	A roof having a slope on all four sides.
Historic District	An area with a significant concentration of buildings, structures, sites unified by past events, physical development, design, setting, materials, workmanship, sense of cohesiveness or related historic and aesthetic associations. The significance of a district is recognized by thorough listing in local, state, and/or national landmarks register and protected locally through enactment of a local historic district ordinance administered by The Brandon Historic Preservation Commission.
Infill	New construction where there had been an opening previously; a new building between two older buildings or new material such as blocking in an original window opening.
Jamb	The side of a doorway or window opening.
Landmarks	<p>Brandon Landmark – a property or structure designated as a landmark by ordinance of the Mayor and Aldermen of the City of Brandon that is worthy of rehabilitation, restoration, and reservation because of its local historic and/or architectural significance.</p> <p>Mississippi Landmark A property or structure designated by the Mississippi Department of Archives and History as being worthy importance to the history of the state.</p> <p>National Historic Landmark – A property or structure designated by the U.S. Department of the Interior as being worthy of rehabilitation because of its importance to the history of the Nation.</p>
Lattice	An openwork grill of interlacing wood strips, usually in a diagonal pattern used as screening.
Light	An individual pane of glass.
Lintel	A beam that spans an opening and is supported on vertical posts at each end. A horizontal structural element over a window or door opening which supports the wall above.
Masonry	Constructed of stone, cement, or brick.
Massing	A term used to define the overall volume of a building.
Mullion	The vertical strip of wood separating the lights of a window.
Muntin	The horizontal strip of wood separating the lights of a window.
Parapet	The uppermost portion of the exterior wall which extends above the roof line. It forms the top line of the building silhouette.
Pediment	A low pitched gable above a portico, door, or window usually with decorative elements or carvings inside the gable portion.
Pier	An upright structure, usually of masonry, which serves as support for the floor joists and walls.

GLOSSARY

Pilaster	A flat vertical support, often treated like a column with a capital, shaft, and base.
Pitch	The degree of slope of a roof.
Porte Cochere	A large covered entrance porch through which cars can drive.
Portico	A small porch that protects an entrance.
Rafters	Structural supports placed at an angle to carry a pitched roof.
Rehabilitation	The act or process of returning a property to a state of utility through repair or alteration which makes possible an efficient contemporary use while preserving those portions or features of the property which are significant to its historic, architectural value.
Renovation	Modernization of an old or historic building that may produce inappropriate alterations or elimination of important features and details.
Ridge	The uppermost intersection of roof slopes, usually at the top of a house; the place where different slopes of a roof meet.
Right of Way	A strip of land acquired by reservation, dedication, purchase, lease or condemnation and occupied by a street, access, sidewalk, railroad, transmission line, utilities, and other features.
Riser	Vertical face of a stair step.
Sash	The portion of a window that holds the glass.
Setback	The distance that a building is located from a street or sidewalk.
Shiplap	Siding with a flat face which is beveled or grooved at the lap.
Sidelight	A narrow vertical window usually found on both sides of a door.
Siding	The material used to cover the exterior of a building to provide a permanent barrier against weather.
Sill	The horizontal member located at the top of a foundation supporting the structure above; also used to describe the horizontal member at the bottom of an opening.
Soffit	The underside of a cornice.
Spacing	The distance between adjacent buildings.
Stucco	An exterior plaster coating applied directly onto masonry, or applied over wood or metal lath to a wood frame structure.
Streetscape	The distinguishing and pictorial character of a particular street as created by its width, degree of curvature and paving materials, design of the street furniture and forms of surrounding buildings.

GLOSSARY

Terra Cotta	Decorative clay units which are fired in molds.
Townscape	The relationship of buildings, shapes, spaces and textures that gives a town or area its distinctive visual character or image.
Transom	A small operable or fixed window located above a door or window.
Tread	Horizontal part of a stair step.
Turned Column	A column that has been turned on a lathe to form rounded bands and shapes.
Vergeboard	The vertical face board following and set under the roof edge of a gable, sometimes decorated by carving.
Vernacular	Characteristic of a locality.

RESOURCES

LOCAL

City of Brandon

Community Development Department
601-825-5021

Issues permits for repair and renovations, as well as for new construction. Interprets and administers the City's zoning ordinances.

Brandon Historic Preservation Commission

P.O. Box 1539
Brandon, MS 39043

Reviews and approves any changes to buildings or any new construction within the Brandon Historic District. Also reviews application for nominations of landmark sites and historic districts and recommendations for such designation to the Mayor and Aldermen. Promotes historic preservation activities and provides technical information concerning rehabilitation.

STATE

Historic Preservation Division

Mississippi Department of Archives and History
P.O. Box 571
Jackson, MS 39205
601-359-6940

State agency responsible for directing and coordinating historic preservation programs in Mississippi

Mississippi Heritage Trust

P.O. Box 571
Jackson, MS 39205

Statewide non-profit organization dedicated to the preservation of Mississippi's cultural resources.

NATIONAL

U.S. Department of the Interior and National Park Service
18th and C Streets, N.W.
Washington, DC 20240
203-343-4621

Federal agency responsible for assuring the identification, protection, and beneficial use of important cultural, natural, and recreational resources. Offers grant assistance, technical information and guidance. Administers such programs as the National Register of Historic Places, State plans and grants, and Technical Preservation services.

RESOURCES

Advisory Council on Historic Preservation

1100 Pennsylvania Avenue, N.W.
202-786-0503

An independent federal agency, the Council is the primary policy advisor to the President and Congress on Historic Preservation. The Council's main function is to review and comment on federal and federally assisted and licensed projects that affect properties listed in or eligible for the National Register of Historic Places, as provided under Section 106 of the National Historic Preservation Act of 1966.

National Trust for Historic Preservation

1785 Massachusetts Avenue, N.W.
Washington, DC 20036
202-673-4000

Private, non-profit national organization chartered by Congress to encourage public participation in the preservation in the preservation of sites, buildings and objects significant in American history and culture. Provides educational assistance and technical aid to those involved in preservation projects.

ADDITIONAL RESOURCES AND REFERENCES

Brandon: A Pictorial History published in 2002, by the Brandon Historical and Genealogical Society
Rankin County Historical Society Calendars 1988 – 2005
Rankin County Chancery Clerk and Official Records
Rankin County Tax Assessor and Official Records
Rankin County News and Marcus Bowers